

# INSTRUCTION MANUAL



## Crawler system

**FWL 100**

**FWL 150**

## Imprint

RIEZLER Inspektionssysteme GmbH & Co. KG  
Sportplatzweg 5  
87471 Kempten / Durach  
Germany

Tel.: +49 (831) 27714

Fax: +49 (831) 17031

Email: [info@riezler.eu](mailto:info@riezler.eu)

All rights reserved.

This documentation shall not be modified, amended, copied or forwarded to third parties without prior written approval by RIEZLER Inspektionssysteme GmbH & Co.KG.

All product designations in this document may be trademarks or product names of the according companies whose use by third parties for their own purposes could violate the rights of the owners.

Technical changes and mistakes are always reserved and can be changed anytime without informing the customer.

Copyright © 2013, RIEZLER Inspektionssysteme GmbH & Co. KG





**Content**

- 1. Icon explanation .....4**
- 2. Range of application .....5**
  - 2.1. Permitted range of application ..... 5
  - 2.2. Prohibited range of application..... 5
- 3. Safety instructions .....6**
- 4. Warning notices .....6**
- 5. Notes of disposal .....7**
- 6. Hints for the use of this operating instruction .....7**
- 7. Installation .....8**
  - 7.1. Camera head assembly ..... 8
  - 7.2. Camera cable assembly ..... 9
  - 7.3. Locating sender assembly ..... 10
  - 7.4. Crawler internal pressure ..... 11
    - 7.4.1. Air pump..... 11
  - 7.5. Wheel assembly FWL 100 ..... 12
  - 7.6. Wheel assembly FWL 150 ..... 13
    - 7.6.1. Spare wheel D160 ..... 13
    - 7.6.2. Spare wheel D220 ..... 14
  - 7.7. Extra search light assembly..... 16
  - 7.8. Camera elevator assembly FWL 100..... 18
  - 7.9. Lift hook assembly FWL 100 ..... 20
- 8. Startup operations .....21**
  - 8.1. Apply cable guide..... 22
  - 8.2. Using the lift hook ..... 23
    - 8.2.1. FWL 100 – without camera elevator..... 23
    - 8.2.2. FWL 100 – with camera elevator ..... 24
    - 8.2.3. FWL 150 ..... 25
- 9. Servicing.....26**
- 10. Guarantee declaration .....27**
  - 10.1. Scope of the guarantee..... 27
  - 10.2. Guarantee conditions ..... 27
- 11. FWL 100: wheels and accessories.....28**
- 12. FWL 150: wheels and accessories.....29**
- 13. Technical data .....30**

## I. ICON EXPLANATION

Warning notices in this document are depicted as symbols. The references are initiated with signal words that show the extent of the threat.

The hints must be observed to prevent accidents, personal- and material-damage.

 <b>HAZARD</b>	<b>Hazard label</b> ... points at immediately dangerous situations that can lead to death or severe injuries, if not avoided.
 <b>WARNING</b>	<b>Warning label</b> ... points at possibly dangerous situations that can lead to death or severe injuries, if not avoided.
 <b>CAUTION</b>	<b>Caution label</b> ... points at possibly dangerous situations that can lead to small or minor injuries or property damage of the inspection system, if not avoided.
 <b>HINT</b>	<b>Hint label</b> ... denotes hints that are important for the economical use of the system and should facilitate its handling.
 <b>SERVICING</b>	<b>Servicing label</b> ... denotes hints which explain how to clean and service the system accordingly, to prevent defects and bigger repairs. Proper servicing can increase the durability of the system considerably.

## 2. RANGE OF APPLICATION

The inspection system is comparable to an optical gauge. Please treat it appropriate carefully! It is solely designed for optical inspections of channels and pipes.

As a channel- or pipe cleaning device the inspection system is certainly not suited and is not designed for that. The removal of obstacles with the camera head can lead to heavy defects and make it unserviceable.

### 2.1. Permitted range of application

Consider that only cleaned channels / pipes are suitable for a proper, decent optical inspection:

- Rainwater sewage pipe systems
- Slop- and mixed water sewage pipe systems
- Industrial effluent sewage pipe systems (only when purged according to §54 WHG)

### 2.2. Prohibited range of application

<b>Danger to life if used in dangerous environments</b>	
 <b>HAZARD</b>	<ul style="list-style-type: none"><li>▪ The inspection system must not be used in gas conduits without particular arrangements!</li><li>▪ The control unit must not be operated in water or conductive materials!</li><li>▪ Environments with explosive gases must not be inspected with the inspection system under any circumstances!</li></ul>

<b>Danger through inappropriate use</b>	
 <b>WARNING</b>	<ul style="list-style-type: none"><li>▪ The inspection system must not be deployed into drinking water pipelines without particular precautions!</li><li>▪ The inspection system must not be operated in environments where groceries are manufactured or processed!</li><li>▪ Has the system been used in an environment with slop, it has to be cleaned thoroughly, before it is allowed to use it in fresh water areas again. Without cleaning this is strictly prohibited, as it can come to infections and fresh water contamination!</li></ul>

### 3. SAFETY INSTRUCTIONS

Read the safety instructions thoroughly and follow them! They serve your own security, the security of your staff and also the prevention of damages to the inspection system and its components.

**Deadly hazard through electric current**



**HAZARD**

- Ensure that no liquid ingresses into the control unit, the control desk or the casings of the camera drums!  
If it happens disconnect the current supply immediately and secure the connector against further connections. Inform the suitably qualified professionals or your RIEZLER service!
- Ensure that the electrical connection cables are undamaged and can't get creased or squashed! If you detect damages disconnect the current supply immediately and secure the connector against further connections. Inform the suitably qualified professionals or your RIEZLER service!
- Works on the electric – which exceed the normal cleaning and maintenance of regular operators – may only be done by skilled professionals. Further maintenance- and repair works must only be realized by the RIEZLER customer service or from RIEZLER Inspektionssysteme authorized persons.
- Switch the system and all peripheral devices dead while doing maintenance.

### 4. WARNING NOTICES

Our products are built very robust so you can work with them for a long period of time. Nevertheless there are a few issues we would like you to obey, because they could otherwise decrease the durability of our products.

**Carefully use**





**CAUTION**

- Always switch off the inspection system first via the Power-button before disconnecting the power cable!
- Before changing pluggable camera heads the system has to be switched off!
- Don't put heavy objects on the device!
- Don't let products fall!
- Never open the product, as long as you are not particularly asked to do it from the operating instruction or from one of our technicians! In the system inside are no parts that can be maintained by a user.

## 5. NOTES OF DISPOSAL

Drained batteries don't belong in the domestic waste. Bring them to a suitable collecting point or return them to your retailer.

Disposal of legacy devices		
 HINT		Legacy devices that are marked by the shown symbol must not be disposed in the domestic waste but have to be properly disposed – according to the electrical and electronics equipment law from March 24 <sup>th</sup> 2005. Please bring these devices at the end of their lifetime to the designated public collecting points.

## 6. HINTS FOR THE USE OF THIS OPERATING INSTRUCTION

This operating instruction gives you an overview over our camera heads and their specifications. Furthermore it is described how the accessories have to be handled.

Steering of the crawler	
 HINT	Information about steering the crawler can be found in the operating instruction of your control unit.

## 7. INSTALLATION



HINT

### Plug connection

Always tighten plug connections only hand-tight. Don't use any tools except the operating instruction asks you to!

### 7.1. Camera head assembly

**FWL 100**



**FWL 150**



Camera connection  
& fastening ring

1. Push the fastening ring towards the crawler housing.
2. Attach the camera head hand-tight onto the camera connection.
3. Finally tighten the fastening ring hand-tight, therewith the camera head is connected securely with the crawler.



## 7.2. Camera cable assembly

**FWL 100**

**FWL 150**

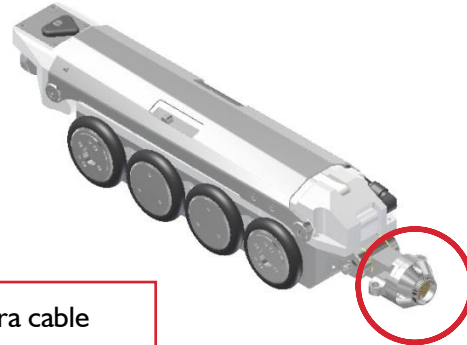

Camera cable  
connection

1. Attach the camera cable (from your cable drum / reel) onto the camera cable connection.

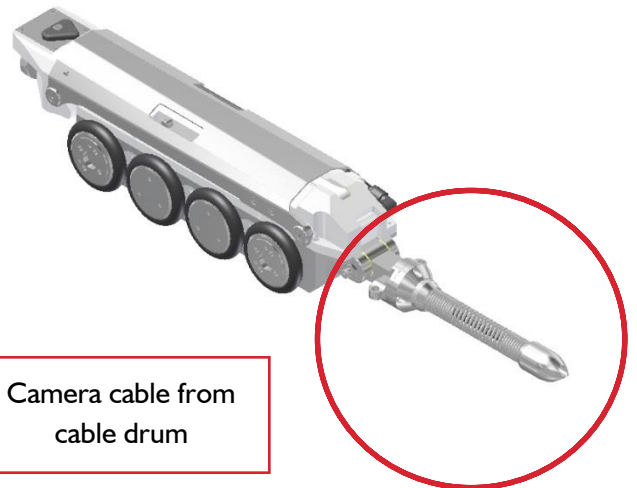
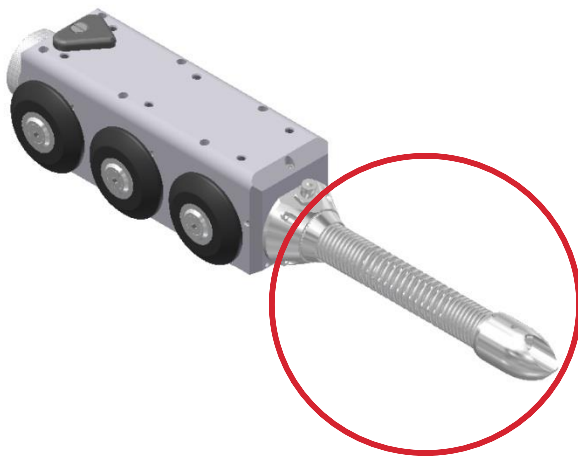

Camera cable from  
cable drum

2. Tighten the fastening ring hand-tight.

## 7.3. Locating sender assembly

Structure of the locating sender:

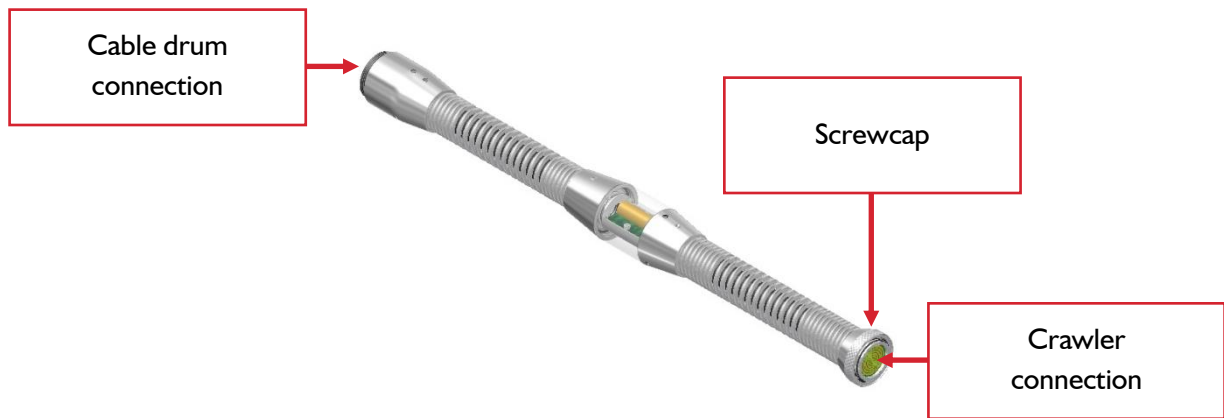

1. Detach the camera cable from the crawler – if it was already attached.

**FWL 100**



Crawler connection /  
screwcap

Connection cable of  
the cable drum

**FWL 150**

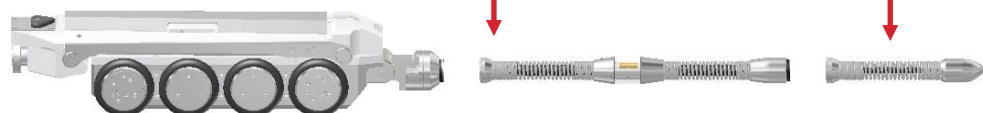

2. Place the end of the locating sender with the screwcap towards the camera connection of the crawler. Tighten the screwcap hand-tight.
3. Connect the connection cable of the cable drum with the locating sender. Tighten this screwcap hand-tight also.

### 7.4. Crawler internal pressure

To increase the internal pressure of the crawler, proceed as following:

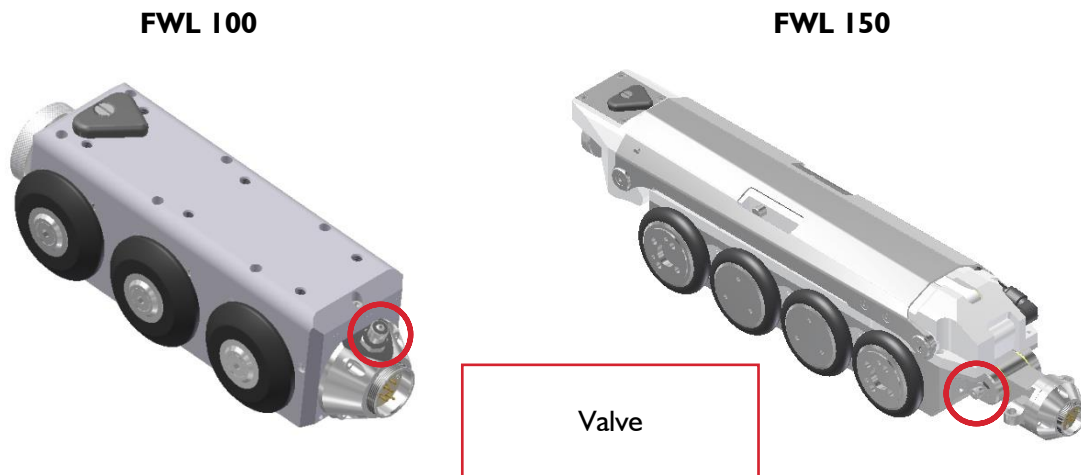

1. Unscrew valve cap which is located at the rear end of the crawler.
2. Place and tighten provided air pump onto the valve of the crawler.
3. Inflate the crawler with two to three pumping movements to a pressure of 1.3 bar.
4. A warning message appears on the screen of your control unit if the pressure is too high (> 1.7 bar). Press with a blunt object (e.g. paper clip) quick into the valve aperture to release air – that lowers the internal pressure.
5. **It's essential to attach the valve cap back onto the valve! Otherwise dirt can get into the valve which will be pressed into the crawler the next time you pump air into it. Thereby the crawler can be damaged severely.**



#### Checking the crawler's internal pressure regularly

Check the internal pressure of the crawler before every inspection! Place the air pump onto the valve and fill the crawler with one pumping movement. Too low pressure enables moisture to get into the crawler and damage it permanently.

#### 7.4.1. Air pump

The air pump possesses an overpressure protection valve. Thereby it's impeded that the crawler gets pumped up to heavily. The air pumps protection valve opens automatically at a pressure of 1.5 bar. Don't cover the protection valve!

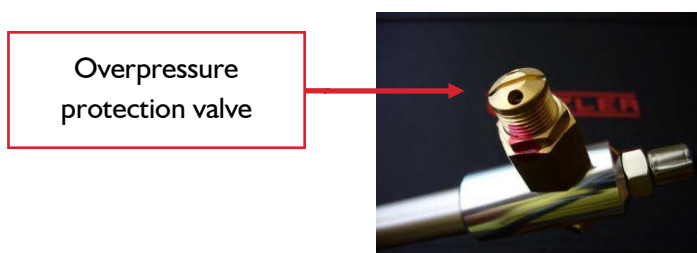

Air pump with overpressure protection valve

### 7.5. Wheel assembly FWL 100

Depending on the pipe diameter it's necessary to mount different wheels onto the crawler. An overview over all available wheels and accessories for the FWL 100 can be found on page 28.

Following it gets explained how to assemble wheels. All wheels of the FWL 100 crawler series get assembled the same way:

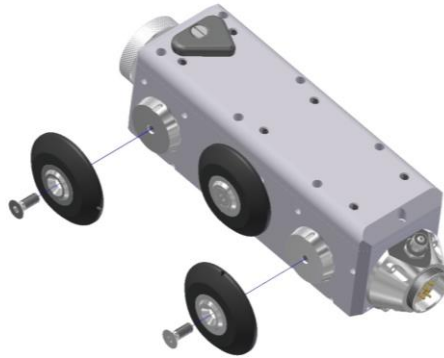

1. Open the hexagon socket bits and remove the four outer basic wheels including the screws of the crawler. Keep the basic wheels and screws in a safe place.



**HINT**

#### Wheel assembly

The middle wheels on both sides of the FWL 100 can remain on the crawler all the time.

2. Attach the new wheels onto the crawler. Assure that the locking pins fit into the notches.

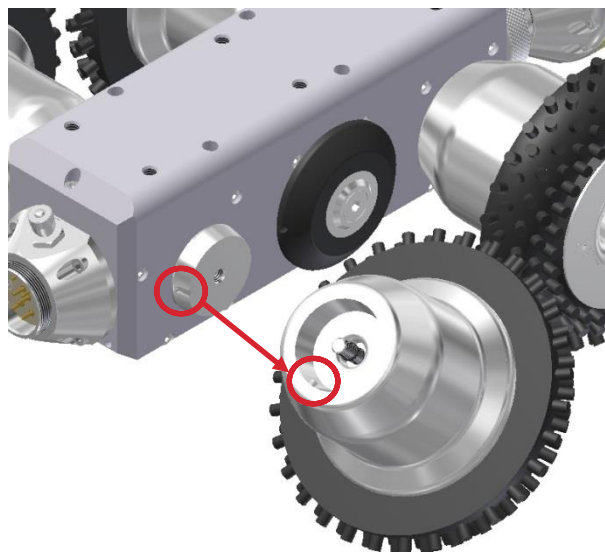

3. Screw the four wheels hand-tight onto the crawler.

### 7.6. Wheel assembly FWL 150

#### 7.6.1. Spare wheel D160

Depending on the pipe diameter it's necessary to mount different wheels onto the crawler. An overview over all available wheels and accessories for the FWL 150 can be found on page 29.

Following it gets explained how to assemble the D160 spare wheels:



1. Place the D160 wheels onto the basic wheels. The basic wheels don't have to be detached.

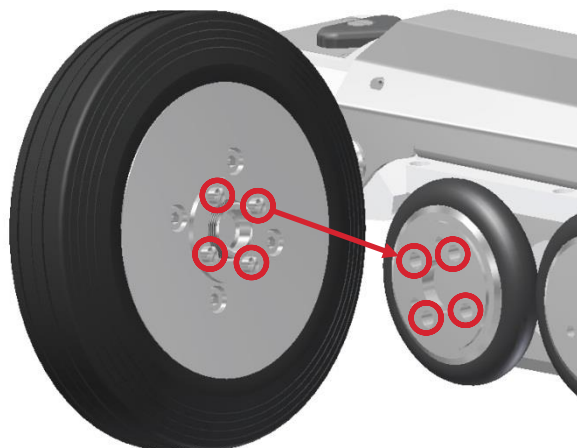

2. Assure that the four locking pins on each wheel fit into the notches of the basic wheels.
3. Screw the four wheels hand-tight onto the crawler.

### 7.6.2. Spare wheel D220

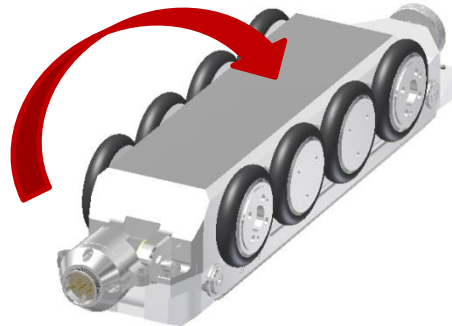

1. Flip the crawler carefully 180 ° on its back. Assure that the camera elevator is on its lowest point.

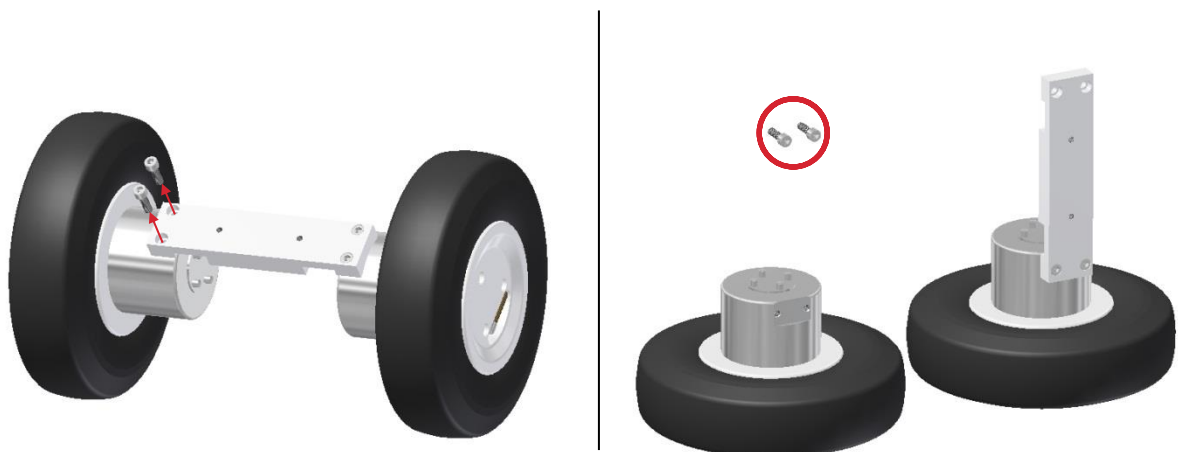

2. Untighten two screws on one side of the connecting plate to detach one wheel of the connecting plate. Keep the two screws in a safe place!
3. Repeat the procedure for the second pair of wheels.



HINT

#### No fastening of the connecting plate

The connecting plate doesn't have to be fastened to the crawler. It is just needed to mount the spare wheels to the crawler.

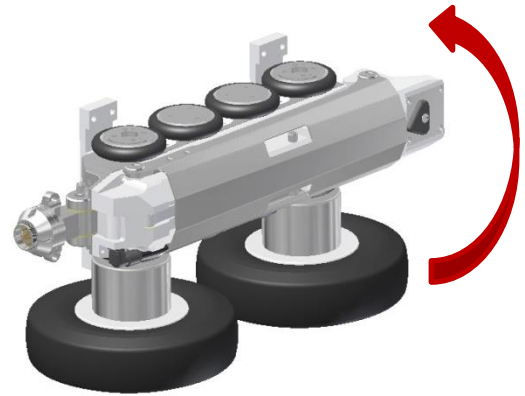
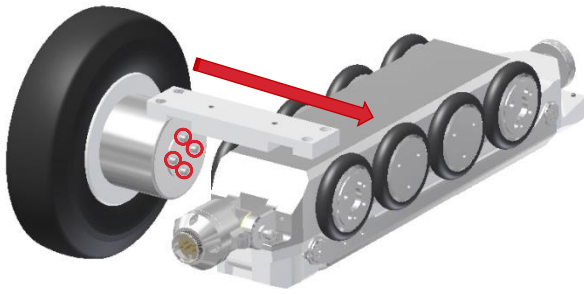

4. Place the spare wheel (which is attached to the connecting plate) on one of the outer basic wheels of the crawler. The four locking pins of the spare wheel have to fit into the four guiding holes of the crawler's basic wheel. The connecting plate rests flat on the bottom of the crawler. Repeat the process for the second pair of spare wheel + connecting plate.
5. Tilt the crawler by 90 ° so it stands on the two pinned spare wheels.

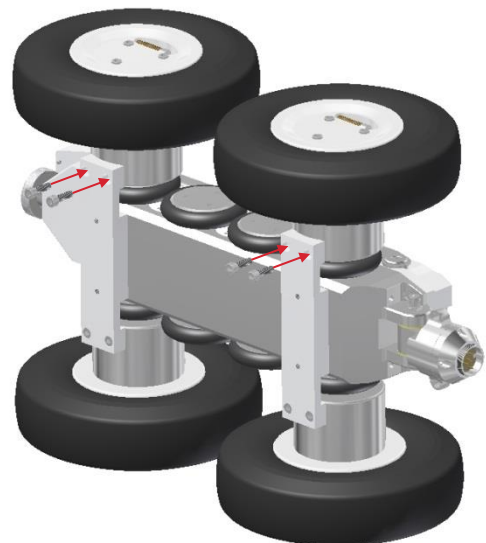
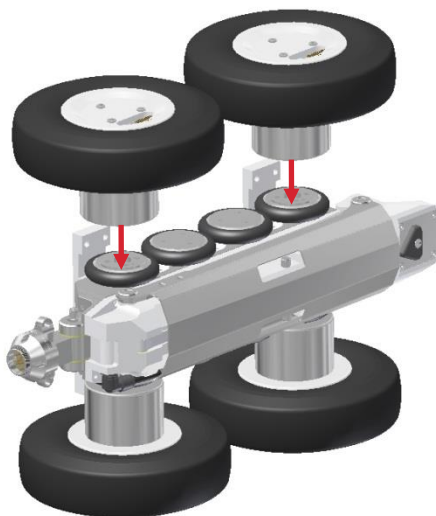

6. Rack the two remaining spare wheels onto the outer basic wheels of the crawler. Assure that the threads of the spare wheels align with the drillings in the connecting plate.
7. Screw the connecting plate with the just pinned on spare wheels together. Tighten the screws hand-tight. Finally tilt the crawler by 90 ° back into its regular position.

### 7.7. Extra search light assembly

FWL 100

FWL 150

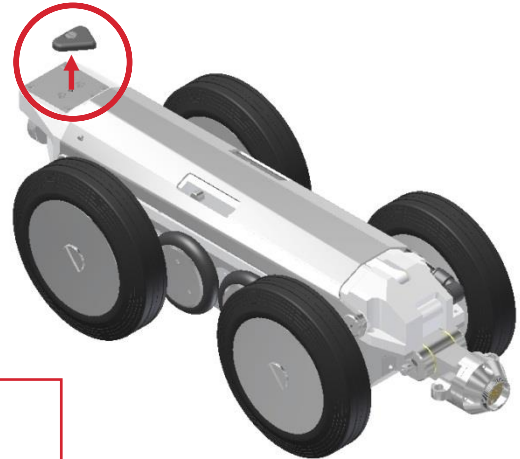
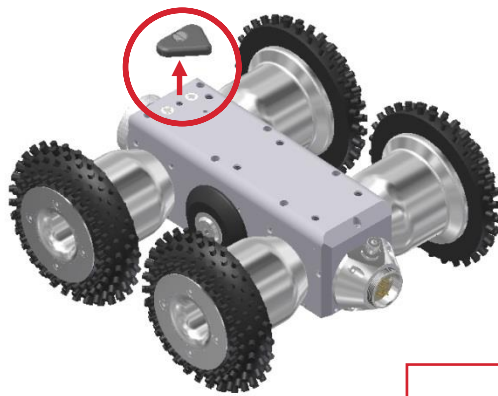

Protection cap

1. Detach the protection cap with a slot screwdriver and keep it in a safe place.

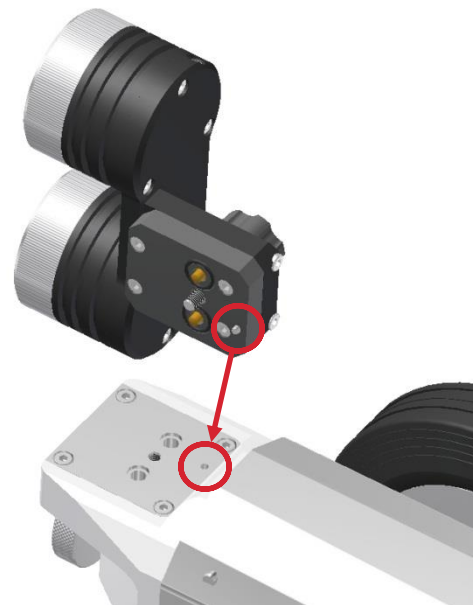
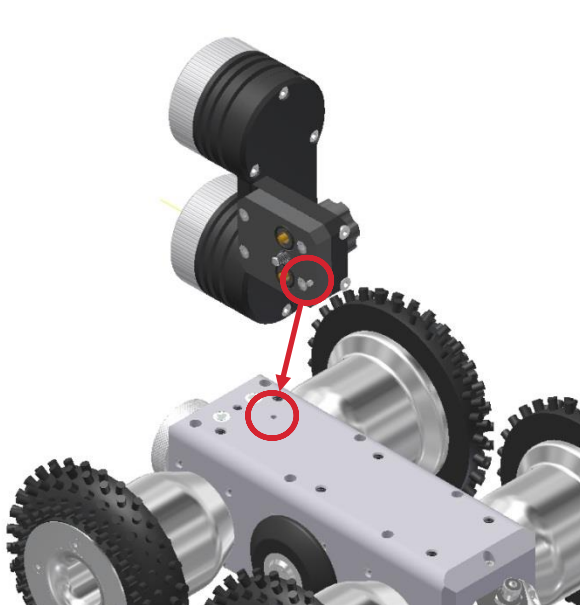

2. Attach the extra search light facing the front of the crawler. Assure that the locking pin fits into the guiding hole.

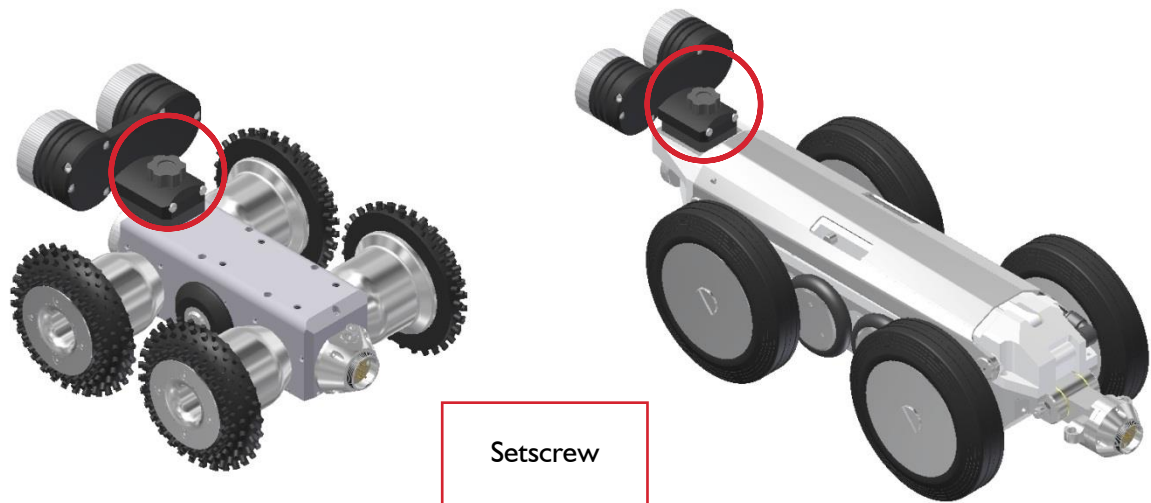

3. Tighten the setscrew hand-tight.

### Protection cap



#### HINT

Locking pin and guiding hole ensure that the electronic contact connection between crawler and extra search light are aligned properly and get protected from oxidation.

Reattach the protection cap onto its regular place when you detach the extra search light of the crawler.

## 7.8. Camera elevator assembly FWL 100

Structure of the camera elevator:

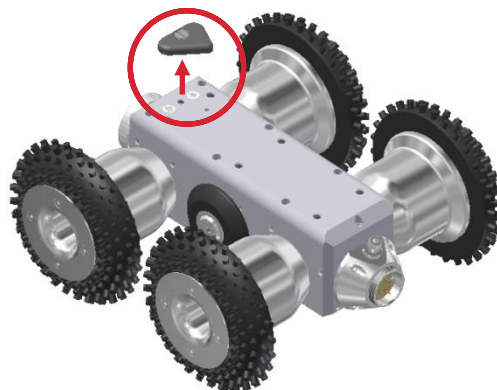
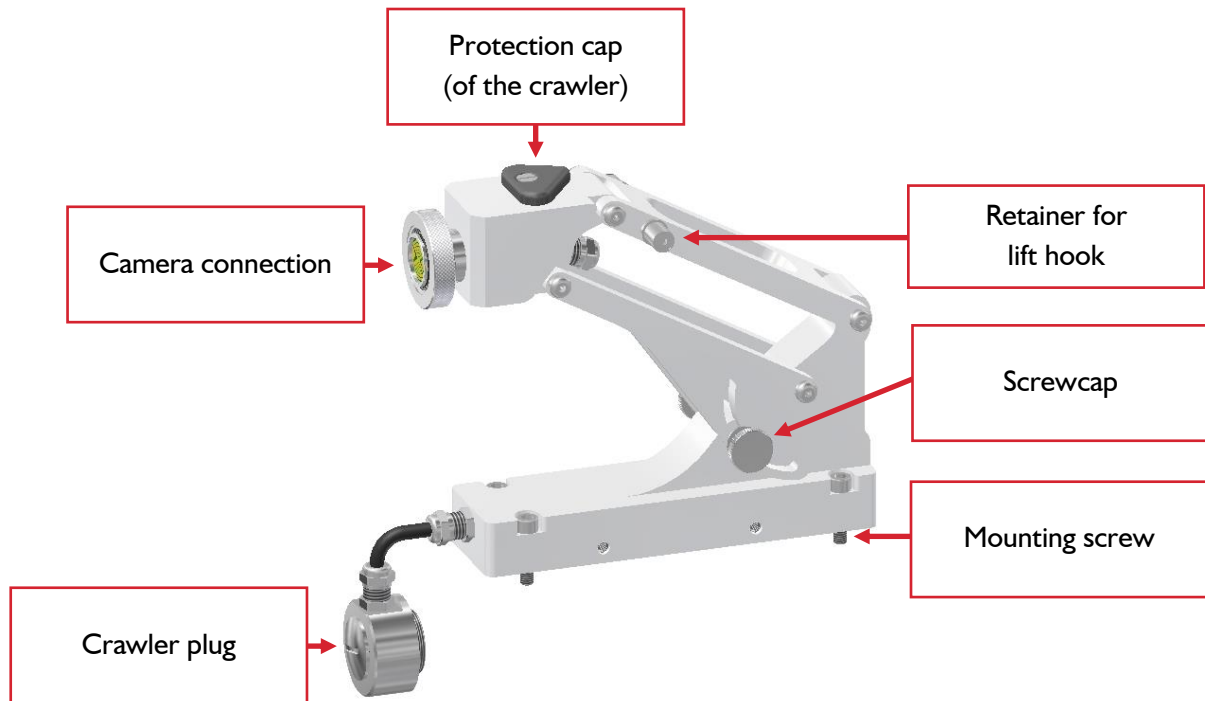

1. Detach the protection cap with a slot screwdriver and keep it in a safe place.
2. Attach the camera elevator onto the crawler through the four fastening screws. The crawler connection and camera plug have to face the front of the crawler.
3. Connect the crawler plug with the crawler and tighten the screwcap hand-tight.
4. Connecting the camera head follows the same way as described in „7.1. Camera head assembly“ on page 8.

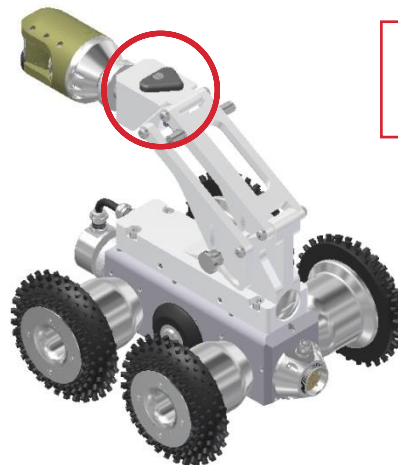

Protection cap

5. Mount the protection cap, which you removed from the crawler, onto the camera elevator.



HINT

### Protection cap

The protection cap protects the electrical contacts on the camera elevator from oxidation.



6. If needed attach the extra search light onto the camera elevator. The installation is the same as described in point 7.7. on page 16.

## 7.9. Lift hook assembly FWL 100

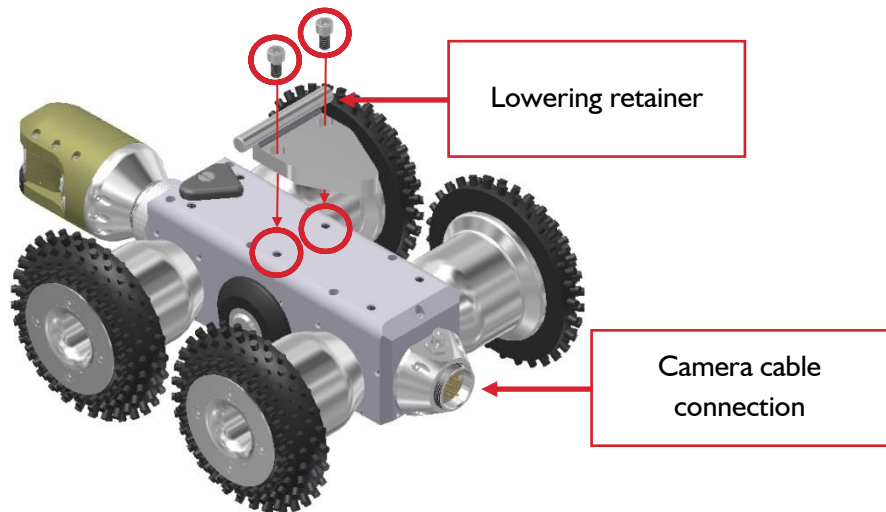

1. Place the lowering retainer centered on the FWL 100 crawler – as depicted on the figure above. The narrow converging end of the retainer faces the camera cable connection.

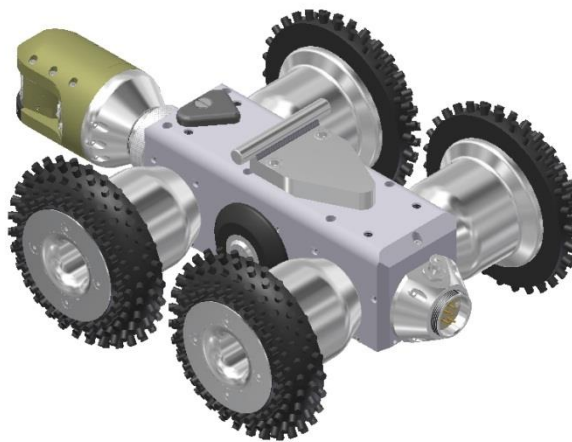

2. Tighten both screws with a suitable screwdriver hand-tight.



### Position of the lift hook

The lowering retainer has to be placed centered on the crawler! You must not place it on the front or back of the crawler - this could lead to tremendous damage on the system!

## 8. STARTUP OPERATIONS

1. Place the crawler in front of the pipe you want to inspect.  
If you want to lower the crawler with the lift hook into the pipe, please read „8.2. Using the lift hook“ on page 23.
2. Adjust the camera elevator of the FWL 100 (if used) to the correct height with help of the screwcaps.
3. Power up the camera system with the camera button [I.I] on the control unit.



HINT

### Steering the crawler

Please see the operating instruction of the control unit for further information about the steering of the crawler.

### 8.1. Apply cable guide

Our camera cables are very robust and abrasion-proof. Nevertheless sharp edges can damage the cable and its jacket when it is dragged over. To prevent this kind of damages we recommend using the cable guide.

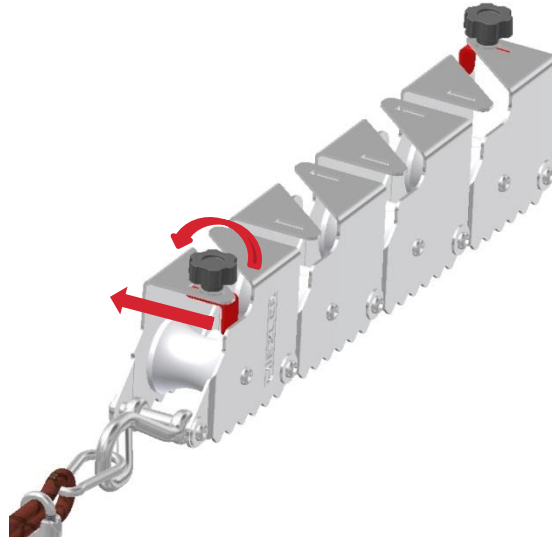

1. Loosen the setscrew with half a turn counter-clockwise and pull it to the back – as shown on the depiction.
2. Repeat the process for the second setscrew.
3. Lead the camera cable through the notch on top of the cable guide.
4. Push both setscrews back into their originally positions and tighten them clockwise hand-tight. Now the camera cable can't escape anymore out of the cable guide.
5. Place the cable guide over the sharp edge.



**HINT**

#### **Subsequent apply of the cable guide**

Thanks to its intelligent design the cable guide can be applied subsequently, even when the crawler is already inside the pipe.

### 8.2. Using the lift hook

#### 8.2.1. FWL 100 – without camera elevator



6. After the lowering retainer has been mounted properly and centered onto the crawler (as shown in point „7.9. Lift hook assembly FWL 100“ on page 20), you can hook in the hook. Thereby it has to be attached as shown on the three pictures above. The open part of the hook faces the camera head. Through this way of hooking it in, it will release itself when the crawler moves forward.
7. Carefully lower the crawler into the pipe.



8. Arrived at the bottom of the pipe, let the hook fall towards the camera head and move the crawler carefully a few centimeters / inches forward. The lift hook moves itself of the retainer and can be pulled up.



HINT

#### Recover the crawler

To recover the crawler follow the bullet points in this topic in reversed order.

Take care that the crawler won't hit the walls when lifting it up / down.

### 8.2.2. FWL 100 – with camera elevator



1. Hook in the hook into the camera elevator as shown on the three pictures above. The open part of the hook has to face the camera head. This simplifies the release of the hook as soon as the crawler is inside of the pipe.
2. Carefully lower the crawler into the pipe.



3. Arrived at the bottom of the pipe, let the hook down a few more centimeters / inches. It unhooks itself of the retainer. Move the hook towards the rear of the crawler and pull it up.



#### HINT

#### Recover the crawler

To recover the crawler follow the bullet points in this topic in reversed order.

Take care that the crawler won't hit the walls when lifting it up / down.

### 8.2.3. FWL 150



1. Hook in the hook into the crawler as shown on the three pictures above. The camera elevator has to be on its lowest point. The open part of the hook has to face the camera head. Through this way of hooking it in, it will release itself when the crawler moves forward.
2. Carefully lower the crawler into the pipe.

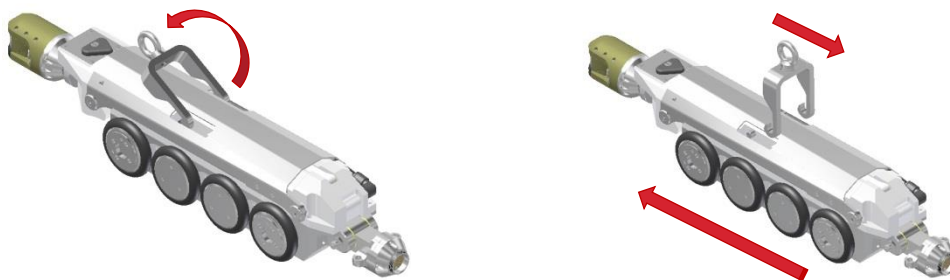

3. Arrived at the bottom of the pipe, let the hook fall towards the camera head and move the crawler carefully a few centimeters / inches forward. The lift hook moves itself of the retainer and can be pulled up.
4. With the push of a button the camera elevator can be moved to the correct height after the crawler has been placed into the pipe.



#### HINT

#### Recover the crawler

To recover the crawler follow the bullet points in this topic in reversed order.

Take care that the crawler won't hit the walls when lifting it up / down.

## 9. SERVICING



**CAUTION**

### Before beginning the cleaning

Before beginning the cleaning you have to switch off the inspection system and disconnect it from any power source! Cover the connectors with the dedicated protection caps.

While winding up the cable use a moist cloth to prevent a buildup of debris. The camera head and the cable must only be cleaned with water and soap. Please do not use solvents. The lighting- and lens glass panel should only be brushed off with a soft cloth or cotton sticks. Never try to scrape soiling off with tools!

The camera cable is specifically engineered and built for our inspection systems. The outer jacket is firm and abrasion-proof and mostly resistant to outside influences. But inappropriate handling or adverse conditions can damage or destroy this jacket. If the cable is damaged it has to be checked and possibly be exchanged with a new one.



**WARNING**

### Damaged cable

A damaged jacket facilitates the penetration of moisture into the cable and can lead to a failure of the inspection system. If inner cable cores are damaged electrical shorts can occur!

In this case decommission the inspection system immediately!



**HINT**

### Prevent damages

- Never use a high pressure cleaner to clean the inspection system. This can lead to considerable damages on the product.
- Especially clean screens and camera lenses extremely cautious and refrain from using caustic detergents.

## **10. GUARANTEE DECLARATION**

Congratulations on the purchase of your new RIEZLER inspection system. Our devices are the result of years of experience and ongoing development.

Conscientious workmanship and control are important goals in our company. Nonetheless if defects should occur, the possibility of which can never be excluded, you have a high level of security through our generous guarantee.

Please note, however, that even the best product can properly and continuously fulfill its function only if it is properly maintained and operated.

### 10.1. Scope of the guarantee

For the product from RIEZLER Inspektionssysteme GmbH & Co. KG that you have purchased, that has been manufactured and tested in accordance with our production and quality guidelines we grant you a guarantee of twelve months.

We will correct defects that occur verifiably due to material and/or manufacturing faults at no charge. In this regard we reserve the right, at our sole discretion, to repair the device, or to replace it completely, replace its defective parts, or refund the remaining value to the customer, if repair or replacement is not possible.

### 10.2. Guarantee conditions

The equipment may not be opened without the consent of the manufacturer. Non-compliance with this regulation voids any claim under warranty. Changes to the equipment also void the warranty.

The warranty starts on the day of the delivery.

Excepted from the guarantee are damages that occur due to improper use of the system, inadequate maintenance, normal wear, and force majeure (e.g. lightning, fire, and freezing...).





Moreover the guarantee does not cover parts that are subject to wear, such as front glass, shaft end seals, lights, cables, etc., as well as damage that does not impair the serviceability of the system.

If you have a guarantee claim please contact us, your dealer, or the service organization closest to you, and submit the original invoice.

## II. FWL 100: WHEELS AND ACCESSORIES

Label / product number	Figure	Nominal diameter in mm / inch					
		150 / 5.90	200 / 7.87	300 / 11.81	400 / 15.74	500 / 19.68	600 / 23.62
Wheel D63 5-0021-501		✓					
Wheel D97 5-0021-502			✓				
Wheel D100 5-0021-503			✓				
Wheel D117 5-0021-504				✓	✓	✓	✓
Extra LED search light 5-0018-001				✓	✓	✓	✓
Camera elevator 5-0019-001				✓	✓	✓	✓
Lift hook with holder 5-0016-504		<p>The lift hook helps you to lower and rescue the crawler into / from ducts. Thereby it is designed to unhook itself automatically from the crawler when he moves forward.</p> <p>Included in the delivery is a 10 m / 32.8 ft rope.</p>					
Cable guide 5-0032-001		<p>The stainless steel cable guide protects your camera cable from sharp edges and mechanical damages when operating a crawler in ducts. The cable guide can even get applied when the crawler is already in the duct.</p> <p>Included in the delivery is a 10 m / 32.8 ft rope.</p>					

## 12. FWL 150: WHEELS AND ACCESSORIES

Label / product number	Figure	Nominal diameter in mm / inch						
		300 / 11.81	400 / 15.75	500 / 19.69	600 / 23.62	800 / 31.50	1000 / 39.37	1200 / 47.24
Wheel D160 5-0022-500		✓	✓	✓	✓			
Wheel D220 5-0022-502						✓	✓	✓
Extra LED search light 5-0018-001		✓	✓	✓	✓	✓	✓	✓
Lift hook 5-0022-504		<p>The lift hook helps you to lower and rescue the crawler into / from ducts. Thereby it is designed to unhook itself automatically from the crawler when he moves forward.</p> <p>Included in the delivery is a 10 m / 32.8 ft rope.</p>						
Cable guide 5-0032-001		<p>The stainless steel cable guide protects your camera cable from sharp edges and mechanical damages when operating a crawler in ducts. The cable guide can even get applied when the crawler is already in the duct.</p> <p>Included in the delivery is a 10 m / 32.8 ft rope.</p>						

### 13. TECHNICAL DATA

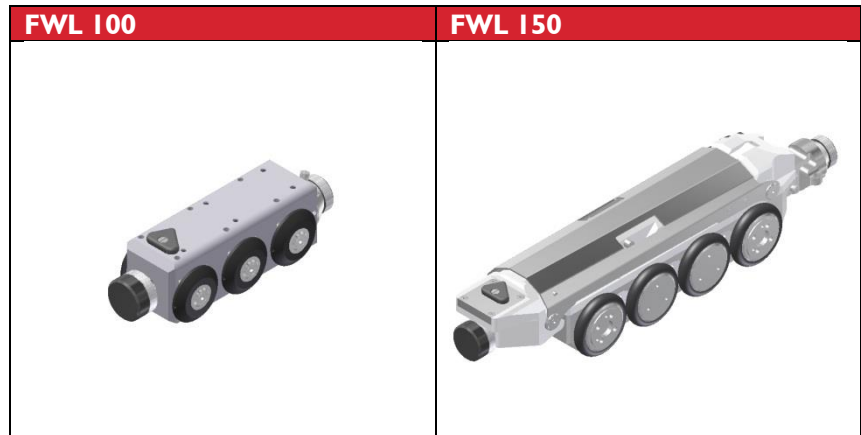

**Features**

Usable from Ø to Ø	100 - 600 mm 3.94 inch - 23.62 inch	150 - 1200 mm 5.90 inch - 47.24 inch
Material	Brass / stainless steel	Aluminum / stainless steel
Engine	2 x BLDC-engine at 30 Watt	2 x BLDC-engine at 50 Watt
Impetus	6 powered wheels	8 powered wheels
Steerable	✓	✓
Pressure-proof till	1 bar	1 bar
Internal pressure surveillance	✓	✓
Tilt measurement long axis	✓	✓
Tilt measurement lateral axis	✓	✓
Power supply	via control unit	via control unit
Dimensions (L x W x H)	240 x 87 x 78 mm 9.45 x 3.43 x 3.07 inch	540 x 130 x 120 mm 21.26 x 5.12 x 4.72 inch
Weight	6,6 kg / 14.55 lbs	18,4 kg / 40.56 lbs

**Compatible camera heads**

RIK 5570	✓	✓
RSK 60100	✓	✓
RSK 78110	✓	✓

**Compatible cable drums**

KTM 150	✓	✓
KTU 180	✓	✓
KTA 250	✓	✓