

Leica TS60/MS60/TM60

Nova



User Manual
Version 6.0
English

- when it has to be **right**

Leica
Geosystems

PART OF
HEXAGON

Introduction

Purchase

Congratulations on the purchase of the Leica TS60/MS60/TM60.



This manual contains important safety directions as well as instructions for setting up the product and operating it. Refer to [1 Safety Directions](#) for further information.

Read carefully through the User Manual before you switch on the product.



The content of this document is subject to change without prior notice. Ensure that the product is used in accordance with the latest version of this document.

Updated versions are available for download at the following Internet address: <https://myworld.leica-geosystems.com> > myDownloads

Product identification

The model and serial number of your product are indicated on the type label. Always refer to this information when contacting your agency or Leica Geosystems authorised service centre.

Trademarks

- Windows® is a registered trademark of Microsoft Corporation in the United States and other countries
- *Bluetooth*® is a registered trademark of Bluetooth SIG, Inc.
- SD Logo is a trademark of SD-3C, LLC.



All other trademarks are the property of their respective owners.

Validity of this manual

This manual applies to all TS60/MS60/TM60 instruments. Where there are differences between the various models they are clearly described.

Available documentation

Name	Description/Format		
MS60/TS60/TM60 Quick Guide	Provides an overview of the product together with technical data and safety directions. Intended as a quick reference guide.	✓	✓
MS60/TS60/TM60 User Manual	All instructions required in order to operate the product to a basic level are contained in the User Manual. Provides an overview of the product together with technical data and safety directions.	-	✓

Name	Description/Format		
Captivate Technical Reference Manual	Overall comprehensive guide to the product and application functions. Included are detailed descriptions of special software/hardware settings and software/hardware functions intended for technical specialists.	-	✓

Refer to the following resources for all MS60/TS60/TM60 documentation/software:

- the Leica USB documentation card
- <https://myworld.leica-geosystems.com>



Video tutorials are available on:

<http://www.leica-geosystems.com/captivate-howto>

Leica Geosystems address book

On the last page of this manual, you can find the address of Leica Geosystems headquarters. For a list of regional contacts, please visit http://leica-geosystems.com/contact-us/sales_support.



<https://myworld.leica-geosystems.com> offers a wide range of services, information and training material.

With direct access to myWorld, you are able to access all relevant services whenever it is convenient for you.

The availability of services depends on the instrument model.

Service	Description
myProducts	Add all products that you and your company own and explore your world of Leica Geosystems: View detailed information on your products and update your products with the latest software and keep up-to-date with the latest documentation.
myService	View the current service status and full service history of your products in Leica Geosystems service centres. Access detailed information on the services performed and download your latest calibration certificates and service reports.
mySupport	Create new support requests for your products that will be answered by your local Leica Geosystems Support Team. View the complete history of your support requests and view detailed information on each request in case you want to refer to previous support requests.
myLearning	Welcome to the home of Leica Geosystems online learning! There are numerous online courses – available to all customers with products that have valid CCPs (Customer Care Packages).

Service	Description
myTrustedServices	Add your subscriptions and manage users for Leica Geosystems Trusted Services, the secure software services, that assist you to optimise your workflow and increase your efficiency.
mySmartNet	Add and view your HxGN SmartNet subscriptions and user information. HxGN SmartNet delivers high-precision and high-availability GNSS network correction services in real time. The HxGN SmartNet Global family offers Network RTK with RTK bridging and Precise Point Positioning (PPP) services. These services work exclusively with Leica Geosystems GS sensors, providing the highest accuracy. Combined, they ensure HxGN SmartNet coverage everywhere.
myDownloads	Downloads of software, manuals, tools, training material and news for Leica Geosystems products.

Table of Contents

PART 1 TS60/MS60/TM60

1	Safety Directions	9
1.1	General Introduction	9
1.2	Definition of Use	10
1.3	Limits of Use	10
1.4	Responsibilities	11
1.5	Hazards of Use	11
1.6	Laser Classification	15
1.6.1	General	15
1.6.2	Distancer, Measurements with Reflectors	15
1.6.3	Distancer, Measurements without Reflectors	16
1.6.4	Red Laser Pointer	17
1.6.5	Autofocus Capability of Telescope Camera	19
1.6.6	Automatic Target Aiming (ATRplus)	20
1.6.7	PowerSearch (PS)	21
1.6.8	Electronic Guide Light (EGL)	22
1.6.9	Laser Plummet	22
1.6.10	AutoHeight Laser Plummet	23
1.7	Electromagnetic Compatibility (EMC)	24
2	Description of the System	27
2.1	System Components	27
2.2	System Concept	30
2.2.1	Software Concept	30
2.2.2	Power Concept	31
2.2.3	Data Storage Concept	31
2.3	Container Contents	32
2.4	Instrument Components	35
3	User Interface	37
3.1	Keyboard	37
3.2	Operating Principles	38
3.3	Autofocus Capability of Telescope Camera	39
4	Operation	41
4.1	Setting Up the TS Instrument	41
4.2	Setting Up SmartStation	42
4.3	Setting Up SmartPole	43
4.4	Setting up for Remote Control	43
4.4.1	Setting up for Remote Control (with the RadioHandle)	43
4.4.2	Setting up for Remote Control (with the TCPS30)	43
4.4.3	Fixing the Field Controller to a Holder and Pole	44
4.4.4	Fixing the CS35 Tablet to a Holder and Pole	46
4.5	Connecting to a Personal Computer	47
4.6	Power Functions	50
4.7	Batteries	51
4.7.1	Operating Principles	51
4.7.2	Battery for the TS Instrument	51
4.8	Working with the Memory Device	52
4.9	LED Indicators	53
4.10	Guidelines for Correct Results	55
5	Check & Adjust	57
5.1	Overview	57

5.2	Preparation	58
5.3	Combined Adjustment (l, t, i, c, ATRplus and Telescope Camera)	59
5.4	Tilting Axis Adjustment (a)	61
5.5	Adjusting the Circular Level of the Instrument and Tribrach	63
5.6	Adjusting the Circular Level of the Prism Pole	64
5.7	Inspecting the Laser Plummet of the Instrument	64
5.8	Servicing the Tripod	65
6	Care and Transport	66
6.1	Transport	66
6.2	Storage	66
6.3	Cleaning and Drying	67
6.4	Maintenance	67
7	Technical Data	68
7.1	Angle Measurement	68
7.2	Distance Measurement with Reflectors	68
7.3	Distance Measurement without Reflectors	70
7.4	Distance Measurement - Long Range (LO mode)	71
7.5	Automatic Target Aiming (ATRplus)	72
7.6	Scanning	74
7.7	PowerSearch (PS)	75
7.8	LOC8 Theft Deterrence and Location Device (optional)	76
7.9	Overview Camera	76
7.10	Telescope Camera	77
7.11	SmartStation	77
	7.11.1 SmartStation Accuracy	77
	7.11.2 SmartStation Dimensions	78
7.12	General Technical Data of the Product	78
7.13	Scale Correction	85
7.14	Reduction Formulas	88
7.15	Conformity to National Regulations	90
	7.15.1 TS60/MS60/TM60	90
	7.15.2 RadioHandle	93
	7.15.3 LOC8 Theft Deterrence and Location Device (optional)	94
	7.15.4 Dangerous Goods Regulations	96
8	Software Licence Agreement/Warranty	97
PART 2 AutoPole		
9	Safety Directions	99
9.1	General Introduction	99
9.2	Definition of Use	100
9.3	Limits of Use	100
9.4	Responsibilities	101
9.5	Hazards of Use	101
9.6	Electromagnetic Compatibility (EMC)	105
10	System Components	107
11	Setting Up AutoPole	108
12	Battery for the AP20	111
13	Software Update	112
14	Working with the AutoPole	113
14.1	Overview	113
14.2	PoleHeight	113
14.3	Tilt Compensation	114

14.4	TargetID	117
15	LED Indicators	119
16	Care and Transport	120
16.1	Transport	120
16.2	Storage	120
16.3	Cleaning and Drying	120
17	Technical Data	122
17.1	PoleHeight	122
17.2	Tilt Compensation	122
17.3	TargetID	124
17.4	General Technical Data of the Product	125
17.5	Conformity to National Regulations	127
18	Software Licence Agreement/Warranty	130

PART 1

TS60/MS60/TM60

1 Safety Directions

1.1 General Introduction

Description

The following directions enable the person responsible for the product, and the person who actually uses the equipment, to anticipate and avoid operational hazards.

The person responsible for the product must ensure that all users understand these directions and adhere to them.

About warning messages





Warning messages are an essential part of the safety concept of the instrument. They appear wherever hazards or hazardous situations can occur.

Warning messages...

- make the user alert about direct and indirect hazards concerning the use of the product.
- contain general rules of behaviour.

For the users' safety, all safety instructions and safety messages shall be strictly observed and followed! Therefore, the manual must always be available to all persons performing any tasks described here.

DANGER, WARNING, CAUTION and **NOTICE** are standardised signal words for identifying levels of hazards and risks related to personal injury and property damage. For your safety, it is important to read and fully understand the following table with the different signal words and their definitions! Supplementary safety information symbols may be placed within a warning message as well as supplementary text.

Type	Description
 DANGER	Indicates an imminently hazardous situation which, if not avoided, will result in death or serious injury.
 WARNING	Indicates a potentially hazardous situation or an unintended use which, if not avoided, could result in death or serious injury.
 CAUTION	Indicates a potentially hazardous situation or an unintended use which, if not avoided, may result in minor or moderate injury.
NOTICE	Indicates a potentially hazardous situation or an unintended use which, if not avoided, may result in appreciable material, financial and environmental damage.
	Important paragraphs which must be adhered to in practice as they enable the product to be used in a technically correct and efficient manner.

Additional symbols



Warning against explosive material.



Warning against flammable substances.



Product must not be opened or modified or tampered with.



Indicates the temperature limits at which the product may be stored, transported or used.

1.2

Definition of Use

Intended use

- Measuring horizontal and vertical angles
- Measuring distances
- Recording measurements
- Capturing and recording images
- Automatic target search, recognition and tracking
- Visualising the aiming direction and vertical axis
- Remote control of product
- Data communication with external appliances
- Measuring raw data and computing coordinates using carrier phase and code signal from GNSS satellites (GNSS systems)
- Recording GNSS and point related data
- Computing with software

Reasonably foreseeable misuse

- Use of the product without instruction
- Use outside of the intended use and limits
- Disabling of safety systems
- Removal of hazard notices
- Opening the product using tools, for example a screwdriver, unless this is permitted for certain functions
- Modification or conversion of the product
- Use after misappropriation
- Use of products with recognisable damage or defects
- Use with accessories from other manufacturers without the prior explicit approval of Leica Geosystems
- Inadequate safeguards at the working site
- Aiming directly into the sun

1.3

Limits of Use

Environment

Suitable for use in an atmosphere appropriate for permanent human habitation. Not suitable for use in aggressive or explosive environments.

WARNING

Working in hazardous areas or close to electrical installations or similar situations

Life Risk.

Precautions:

- ▶ Local safety authorities and safety experts must be contacted by the person responsible for the product before working in such conditions.

1.4

Responsibilities

Manufacturer of the product

Leica Geosystems AG, CH-9435 Heerbrugg, hereinafter referred to as Leica Geosystems, is responsible for supplying the product, including the User Manual and original accessories, in a safe condition.

Person responsible for the product

The person responsible for the product has the following duties:

- To understand the safety instructions on the product and the instructions in the User Manual
- To ensure that the product is used in accordance with the instructions
- To be familiar with local regulations relating to safety and accident prevention
- To stop operating the system and inform Leica Geosystems immediately if the product and the application become unsafe
- To ensure that the national laws, regulations and conditions for the operation of the products are respected

1.5

Hazards of Use

NOTICE

Dropping, misusing, modifying, storing the product for long periods or transporting the product

Watch out for erroneous measurement results.

Precautions:

- ▶ Periodically carry out test measurements and perform the field adjustments indicated in the User Manual, particularly after the product has been subjected to abnormal use as well as before and after important measurements.

DANGER

Risk of electrocution

Because of the risk of electrocution, it is dangerous to use poles, levelling staffs and extensions in the vicinity of electrical installations such as power cables or electrical railways.

Precautions:

- ▶ Keep at a safe distance from electrical installations. If it is essential to work in this environment, first contact the safety authorities responsible for the electrical installations and follow their instructions.



NOTICE

Remote control of product

With the remote control of products, it is possible that extraneous targets will be picked out and measured.

Precautions:

- ▶ When measuring in remote control mode, always check your results for plausibility.

CAUTION

Pointing product toward the sun

Be careful when pointing the product toward the sun, because the telescope functions as a magnifying glass and can injure your eyes and/or cause damage inside the product.

Precautions:

- ▶ Do not point the product directly at the sun.

WARNING

Distraction/loss of attention

During dynamic applications, for example stakeout procedures, there is a danger of accidents occurring if the user does not pay attention to the environmental conditions around, for example obstacles, excavations or traffic.

Precautions:

- ▶ The person responsible for the product must make all users fully aware of the existing dangers.

WARNING

Inadequate securing of the working site

This can lead to dangerous situations, for example in traffic, on building sites and at industrial installations.

Precautions:

- ▶ Always ensure that the working site is adequately secured.
 - ▶ Adhere to the regulations governing safety, accident prevention and road traffic.
-

CAUTION

Not properly secured accessories

If the accessories used with the product are not properly secured and the product is subjected to mechanical shock, for example blows or falling, the product may be damaged or people can sustain injury.

Precautions:

- ▶ When setting up the product, make sure that the accessories are correctly adapted, fitted, secured, and locked in position.
 - ▶ Avoid subjecting the product to mechanical stress.
-

WARNING

Lightning strike

If the product is used with accessories, for example masts, staffs, poles, you may increase the risk of being struck by lightning.

Precautions:

- ▶ Do not use the product in a thunderstorm.
-

WARNING

Inappropriate mechanical influences to batteries

During the transport, shipping or disposal of batteries it is possible for inappropriate mechanical influences to constitute a fire hazard.

Precautions:

- ▶ Before shipping the product or disposing it, discharge the batteries by the product until they are flat.
 - ▶ When transporting or shipping batteries, the person in charge of the product must ensure that the applicable national and international rules and regulations are observed.
 - ▶ Before transportation or shipping, contact your local passenger or freight transport company.
-

⚠ WARNING

Exposure of batteries to high mechanical stress, high ambient temperatures or immersion into fluids

This can cause leakage, fire or explosion of the batteries.

Precautions:

- ▶ Protect the batteries from mechanical influences and high ambient temperatures. Do not drop or immerse batteries into fluids.

⚠ WARNING

Short circuit of battery terminals

If battery terminals are short circuited e.g. by coming in contact with jewellery, keys, metallised paper or other metals, the battery can overheat and cause injury or fire, for example by storing or transporting in pockets.

Precautions:

- ▶ Make sure that the battery terminals do not come into contact with metallic/conductive objects.

⚠ WARNING

Improper disposal

If the product is improperly disposed of, the following can happen:

- If polymer parts are burnt, poisonous gases are produced which may impair health.
- If batteries are damaged or are heated strongly, they can explode and cause poisoning, burning, corrosion or environmental contamination.
- By disposing of the product irresponsibly you may enable unauthorised persons to use it in contravention of the regulations, exposing themselves and third parties to the risk of severe injury and rendering the environment liable to contamination.

Precautions:

▶



The product must not be disposed with household waste. Dispose of the product appropriately in accordance with the national regulations in force in your country. Always prevent access to the product by unauthorised personnel.

Product-specific treatment and waste management information can be received from your Leica Geosystems distributor.

⚠ WARNING

Improperly repaired equipment

Risk of injuries to users and equipment destruction due to lack of repair knowledge.

Precautions:

- ▶ Only authorised Leica Geosystems Service Centres are entitled to repair these products.

1.6 Laser Classification

1.6.1 General

General

The following chapters provide instructions and training information about laser safety according to international standard IEC 60825-1 (2014-05) and technical report IEC TR 60825-14 (2004-02). The information enables the person responsible for the product and the person who actually uses the equipment, to anticipate and avoid operational hazards.

- ☞ According to IEC TR 60825-14 (2004-02), products classified as laser class 1, class 2 and class 3R do not require:
 - laser safety officer involvement
 - protective clothes and eyewear
 - special warning signs in the laser working areaif used and operated as defined in this User Manual due to the low eye hazard level.
- ☞ National laws and local regulations could impose more stringent instructions for the safe use of lasers than IEC 60825-1 (2014-05) and IEC TR 60825-14 (2004-02).

1.6.2 Distancer, Measurements with Reflectors

General

The EDM module built into the product produces a visible laser beam which emerges from the telescope objective.

The laser product described in this section is classified as laser class 1 in accordance with:

- IEC 60825-1 (2014-05): "Safety of laser products"

These products are safe under reasonably foreseeable conditions of operation and are not harmful to the eyes provided that the products are used and maintained in accordance with this User Manual.

Description	Value	
	TS60 TM60	MS60
Wavelength	658 nm	658 nm
Maximum average radiant power	0.33 mW	0.33 mW
Pulse duration	800 ps	700 ps
Pulse repetition frequency (PRF)	100 MHz	1.1 MHz
Beam divergance	1.5 mrad x 3 mrad	1.5 mrad x 3 mrad

A TS60/MS60 instrument is shown.

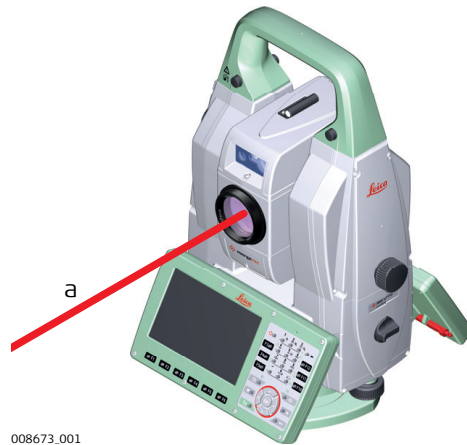

a Laser beam

1.6.3

Distancer, Measurements without Reflectors

General

The EDM module built into the product produces a visible laser beam which emerges from the telescope objective.

The laser product described in this section is classified as laser class 3R in accordance with:

- IEC 60825-1 (2014-05): "Safety of laser products"

Direct intrabeam viewing may be hazardous (low eye hazard level), in particular for deliberate ocular exposure. The beam may cause dazzle, flash-blindness and after-images, particularly under low ambient light conditions. The risk of injury for laser class 3R products is limited because of:

- unintentional exposure would rarely reflect worst case conditions of (e.g.) beam alignment with the pupil, worst case accommodation,
- inherent safety margin in the maximum permissible exposure to laser radiation (MPE)
- natural aversion behaviour for exposure to bright light for the case of visible radiation.

Description	Value	
	TS60 TM60	MS60
Wavelength	658 nm	658 nm
Maximum average radiant power	4.8 mW	1.7 mW
Pulse duration	800 ps	1.5 ns
Pulse repetition frequency (PRF)	100 MHz	RL continuous, RL-Scan: 2 MHz
Beam divergence	0.2 mrad x 0.3 mrad	0.2 mrad x 0.3 mrad
NOHD (Nominal Ocular Hazard Distance) @ 0.25s	44 m / 144 ft	21 m / 69 ft

⚠ CAUTION

Class 3R laser products

From a safety perspective, class 3R laser products should be treated as potentially hazardous.

Precautions:

- ▶ Prevent direct eye exposure to the beam.
- ▶ Do not direct the beam at other people.

⚠ CAUTION

Reflected beams aimed at reflecting surfaces

Potential hazards are not only related to direct beams but also to reflected beams aimed at reflecting surfaces such as prisms, windows, mirrors, metallic surfaces, etc.

Precautions:

- ▶ Do not aim at areas that are essentially reflective, such as a mirror, or which could emit unwanted reflections.
- ▶ Do not look through or beside the optical sight at prisms or reflecting objects when the laser is switched on, in laser pointer or distance measurement mode. Aiming at prisms is only permitted when looking through the telescope.

Labelling

A TS60/MS60 instrument is shown.

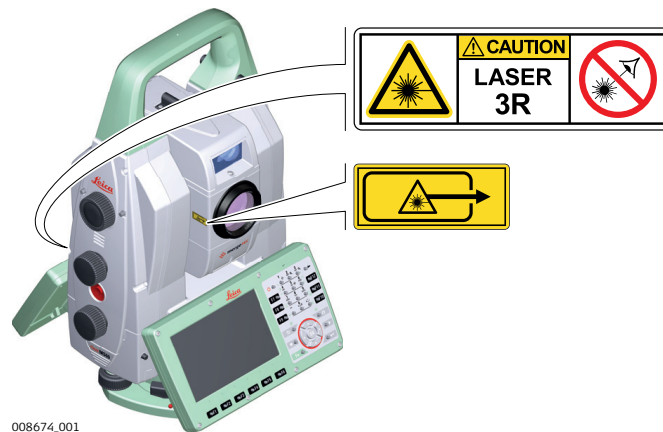

1.6.4

Red Laser Pointer

General

The laser pointer built into the product produces a visible red laser beam which emerges from the telescope objective.

The laser product described in this section is classified as laser class 3R in accordance with:

- IEC 60825-1 (2014-05): "Safety of laser products"

Direct intrabeam viewing may be hazardous (low eye hazard level), in particular for deliberate ocular exposure. The beam may cause dazzle, flash-blindness and after-images, particularly under low ambient light conditions. The risk of injury for laser class 3R products is limited because of:

- a) unintentional exposure would rarely reflect worst case conditions of (e.g.) beam alignment with the pupil, worst case accommodation,
- b) inherent safety margin in the maximum permissible exposure to laser radiation (MPE)
- c) natural aversion behaviour for exposure to bright light for the case of visible radiation.

Description	Value	
	TS60 TM60	MS60
Wavelength	658 nm	658 nm
Maximum average radiant power	4.8 mW	1.7 mW
Pulse duration	800 ps	1.5 ns
Pulse repetition frequency (PRF)	100 MHz	2 MHz
Beam divergence	0.2 mrad x 0.3 mrad	0.2 mrad x 0.3 mrad
NOHD (Nominal Ocular Hazard Distance) @ 0.25s	44 m / 144 ft	21 m / 69 ft

⚠ CAUTION

Class 3R laser products

From a safety perspective, class 3R laser products should be treated as potentially hazardous.

Precautions:

- ▶ Prevent direct eye exposure to the beam.
- ▶ Do not direct the beam at other people.

⚠ CAUTION

Reflected beams aimed at reflecting surfaces

Potential hazards are not only related to direct beams but also to reflected beams aimed at reflecting surfaces such as prisms, windows, mirrors, metallic surfaces, etc.

Precautions:

- ▶ Do not aim at areas that are essentially reflective, such as a mirror, or which could emit unwanted reflections.
- ▶ Do not look through or beside the optical sight at prisms or reflecting objects when the laser is switched on, in laser pointer or distance measurement mode. Aiming at prisms is only permitted when looking through the telescope.

Labelling

A TS60/MS60 instrument is shown.

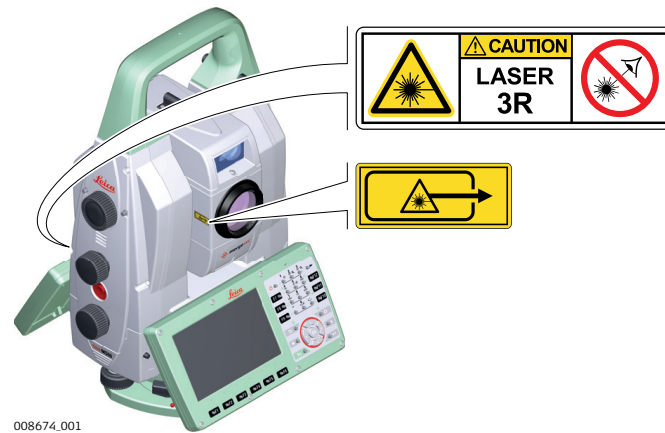

1.6.5

Autofocus Capability of Telescope Camera

General

TS60/MS60/TM60 I contain a coaxial telescope camera with autofocus capability.

When using the auto focus functions a visible laser beam may emerge from the telescope (depending on the focussing mode).

The laser product described in this section is classified as laser class 1 in accordance with:

- IEC 60825-1 (2014-05): "Safety of laser products"

These products are safe under reasonably foreseeable conditions of operation and are not harmful to the eyes provided that the products are used and maintained in accordance with this User Manual.

Description	Value	
	TS60 TM60 I	MS60
Wavelength	658 nm	658 nm
Maximum average radiant power	0.37 mW	0.1 mW
Pulse duration	800 ps	1.5 ns
Pulse repetition frequency (PRF)	100 MHz	Irregular packages max. 670 kHz
Beam divergence	0.2 mrad x 0.3 mrad	0.2 mrad x 0.3 mrad

A TS60/MS60 instrument is shown.

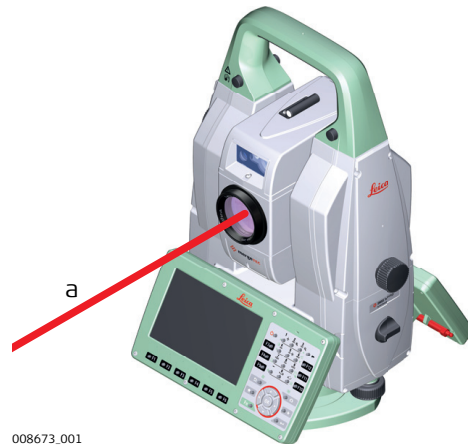

008673_001

a Laser beam

1.6.6

Automatic Target Aiming (ATRplus)

General

The Automatic Target Aiming built into the product produces an invisible laser beam which emerges from the telescope objective.

The laser product described in this section is classified as laser class 1 in accordance with:

- IEC 60825-1 (2014-05): "Safety of laser products"

These products are safe under reasonably foreseeable conditions of operation and are not harmful to the eyes provided that the products are used and maintained in accordance with this User Manual.

Description	Value		
	TS60	TM60	MS60
Wavelength	785 nm	785 nm	785 nm
Maximum radiant peak power per pulse	10 mW	6 mW	10 mW
Pulse duration	≤19.98 ms	≤19.98 ms	≤19.98 ms
Pulse repetition frequency (PRF)	≤213 Hz	≤28.06 Hz	≤213 Hz
Beam divergence	25 mrad	11 mrad	25 mrad

A TS60/MS60 instrument is shown.

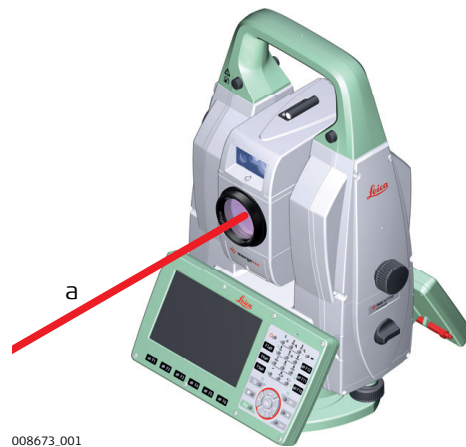

a Laser beam

1.6.7

PowerSearch (PS)



This chapter is valid for TS60/MS60.

General

The PowerSearch built into the product produces an invisible laser beam which emerges from the front side of the telescope.

The laser product described in this section is classified as laser class 1 in accordance with:

- IEC 60825-1 (2014-05): "Safety of laser products"

These products are safe under reasonably foreseeable conditions of operation and are not harmful to the eyes provided that the products are used and maintained in accordance with this User Manual.

Description	Value
Wavelength	850 nm
Maximum average radiant power	11 mW
Pulse duration	20 ns, 40 ns
Pulse repetition frequency (PRF)	24.4 kHz
Beam divergence	0.4 mrad × 700 mrad

A TS60/MS60 instrument is shown.

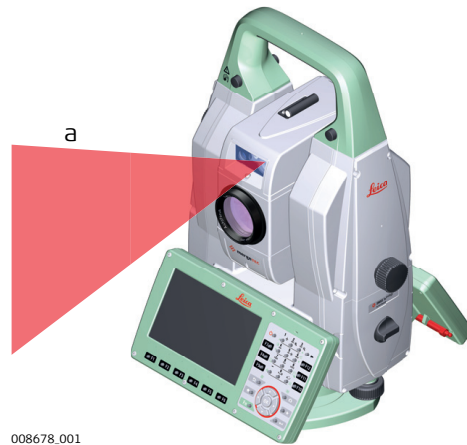

008678_001

a Laser beam

1.6.8

Electronic Guide Light (EGL)



This chapter is valid for TS60/MS60.

General

The Electronic Guide Light built into the product produces a visible LED beam which emerges from the front side of the telescope.



The product described in this section, is excluded from the scope of IEC 60825-1 (2014-05): "Safety of laser products".

The product described in this section, is classified as exempt group in accordance with IEC 62471 (2006-07) and does not pose any hazard provided that the product is used and maintained in accordance with this user manual.

A TS60/MS60 instrument is shown.

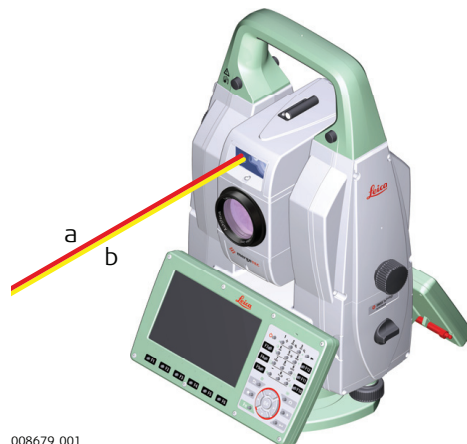

008679_001

a LED beam red
b LED beam yellow

1.6.9

Laser Plummet

General

The laser plummet built into the product produces a visible red laser beam which emerges from the bottom of the product.

The laser product described in this section is classified as laser class 2 in accordance with:

- IEC 60825-1 (2014-05): "Safety of laser products"

These products are safe for momentary exposures but can be hazardous for deliberate staring into the beam. The beam may cause dazzle, flash-blindness and after-images, particularly under low ambient light conditions.

Description	Value
Wavelength	640 nm
Maximum average radiant power	0.95 mW
Pulse duration	0.1 ms - cw
Pulse repetition frequency (PRF)	1 kHz
Beam divergence	<1.5 mrad

⚠ CAUTION

Class 2 laser product

From a safety perspective, class 2 laser products are not inherently safe for the eyes.

Precautions:

- ▶ Avoid staring into the beam or viewing it through optical instruments.
- ▶ Avoid pointing the beam at other people or at animals.

Labelling

A TS60/MS60 instrument is shown.

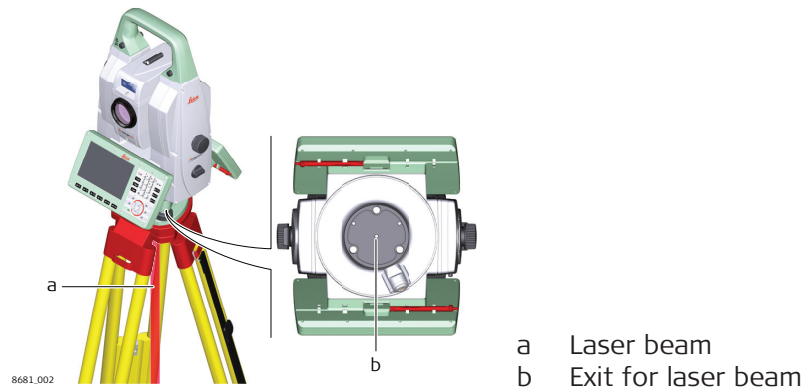

1.6.10

AutoHeight Laser Plummet



This chapter is valid for TS60/MS60.

General

The laser plummet built into the product produces a visible red laser beam which emerges from the bottom of the product.

The laser product described in this section is classified as laser class 2 in accordance with:

- IEC 60825-1 (2014-05): "Safety of laser products"

These products are safe for momentary exposures but can be hazardous for deliberate staring into the beam. The beam may cause dazzle, flash-blindness and after-images, particularly under low ambient light conditions.

Description	Value
Wavelength	640 nm

Description	Value
Maximum average radiant power	0.95 mW
Pulse duration	<1 ns
Pulse repetition frequency (PRF)	320 MHz
Beam divergance	<1.5 mrad

⚠ CAUTION

Class 2 laser product

From a safety perspective, class 2 laser products are not inherently safe for the eyes.

Precautions:

- ▶ Avoid staring into the beam or viewing it through optical instruments.
- ▶ Avoid pointing the beam at other people or at animals.

Labelling

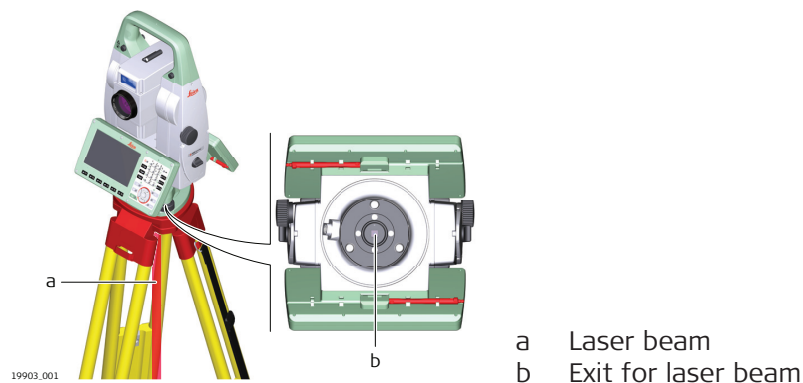

1.7

Electromagnetic Compatibility (EMC)

Description

The term Electromagnetic Compatibility is taken to mean the capability of the product to function smoothly in an environment where electromagnetic radiation and electrostatic discharges are present, and without causing electromagnetic disturbances to other equipment.

⚠ CAUTION

Electromagnetic radiation

Electromagnetic radiation can cause disturbances in other equipment.

Precautions:

- ▶ Although the product meets the strict regulations and standards which are in force in this respect, Leica Geosystems cannot completely exclude the possibility that other equipment may be disturbed.

 **CAUTION**

Use of the product with accessories from other manufacturers. For example, field computers, personal computers or other electronic equipment, non-standard cables or external batteries

This may cause disturbances in other equipment.

Precautions:

- ▶ Use only the equipment and accessories recommended by Leica Geosystems.
- ▶ When combined with the product, other accessories must meet the strict requirements stipulated by the guidelines and standards.
- ▶ When using computers, two-way radios or other electronic equipment, pay attention to the information about electromagnetic compatibility provided by the manufacturer.

 **CAUTION**

Intense electromagnetic radiation. For example, near radio transmitters, transponders, two-way radios or diesel generators

Although the product meets the strict regulations and standards which are in force in this respect, Leica Geosystems cannot completely exclude the possibility that the function of the product may be disturbed in such an electromagnetic environment.

Precautions:

- ▶ Check the plausibility of results obtained under these conditions.

 **CAUTION**

Electromagnetic radiation due to improper connection of cables

If the product is operated with connecting cables, attached at only one of their two ends, the permitted level of electromagnetic radiation may be exceeded and the correct functioning of other products may be impaired. For example, external supply cables or interface cables.

Precautions:

- ▶ While the product is in use, connecting cables, for example product to external battery or product to computer, must be connected at both ends.

 **WARNING**

Use of product with radio or digital cellular phone devices

Electromagnetic fields can cause disturbances in other equipment, installations, medical devices, for example pacemakers or hearing aids, and aircrafts. Electromagnetic fields can also affect humans and animals.

Precautions:

- ▶ Although the product meets the strict regulations and standards which are in force in this respect, Leica Geosystems cannot completely exclude the possibility that other equipment can be disturbed or that humans or animals can be affected.
 - ▶ Do not operate the product with radio or digital cellular phone devices in the vicinity of filling stations or chemical installations, or in other areas where an explosion hazard exists.
 - ▶ Do not operate the product with radio or digital cellular phone devices near medical equipment.
 - ▶ Do not operate the product with radio or digital cellular phone devices in aircrafts.
 - ▶ Do not operate the product with radio or digital cellular phone devices for long periods with the product immediately next to your body.
-

2

Description of the System

2.1

System Components

Main components

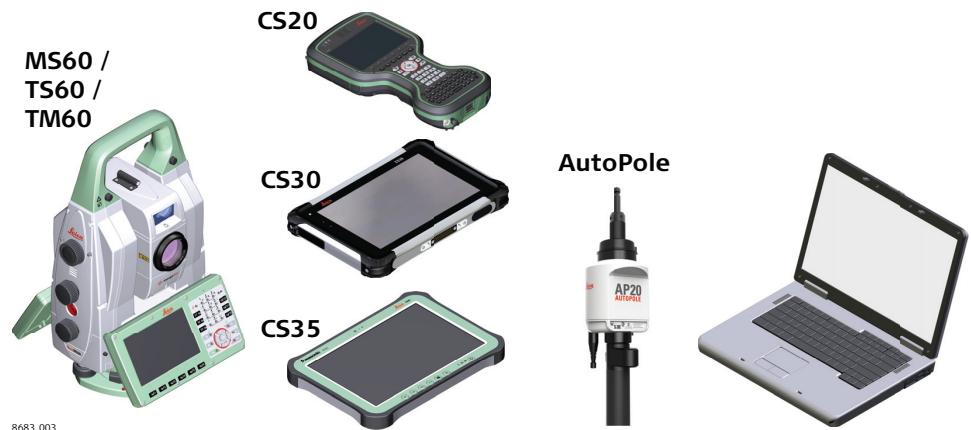

Component	Description
MS60/TS60/TM60	<ul style="list-style-type: none">an instrument for measuring, calculating and capturing data.comprised of various models with a range of accuracy classes.integrated with an add-on GNSS system to form SmartStation.combined with the multi-purpose CS20 field controller, the CS30 tablet or the CS35 tablet to conduct remote control surveys.connected with Infinity to view, exchange and manage data.
CS20 field controller	A multipurpose 5" screen field controller allowing the remote control of MS60/TS60/TM60.
CS30 tablet	A 7" tablet allowing the remote control of the MS60/TS60/TM60 instrument.
CS35 tablet	A 10.1" tablet allowing the remote control of MS60/TS60/TM60.
AutoPole (AP)	A product group with active sensor components which can be attached to AP Reflector Poles. The AP can communicate with total station, field controller or tablet.
AP Reflector Pole	A dedicated group of reflector poles with passive sensing elements inside, capable to carry an AutoPole. Without AutoPole, an AP Reflector Pole can also be used as conventional pole.
Infinity	An office software consisting of a suite of standard and extended programs for the viewing, exchange and management of data.

Terms and abbreviations

The following terms and abbreviations can be found in this manual:

Term	Description
Remote Mode	The instrument is remote controlled by the field controller or tablet using radio.
EDM	<p>Electronic Distance Measurement</p> <p>EDM refers to the laser distancer incorporated into the instrument which enables distance measurement.</p> <p>Two measuring modes are available:</p> <ul style="list-style-type: none"> • Prism mode. This mode refers to the ability to measure distances to prisms. On the TS60/TM60, it incorporates the long range mode to measure extended distances to prisms. On the MS60, the standard mode (Once) is used for the whole distance range including extended distance prisms. • Any surface mode. This mode refers to the ability to measure distances without prisms.
PinPoint	PinPoint refers to the Reflectorless EDM technology which enables an increased measuring range with a smaller laser spot size. Two options are available: R1000 and R2000.
EGL	<p>Electronic Guide Light</p> <p>An EGL fitted to an instrument assists with prism targeting. It consists of two differently coloured flashing lights located in the instrument telescope housing. The person holding the prism can align themselves into the line-of-sight of the instrument.</p>
ATRplus	<p>Automatic Target Aiming</p> <p>ATRplus refers to the instrument sensor which enables the automatic aiming and locking.</p>
Autofocus	Instruments equipped with autofocus offer an automatic focussing of the telescope optics.
Automated	<p>Instruments fitted with ATRplus are referred to as Automated.</p> <p>ATRplus refers to the instrument sensor which enables the automatic target aiming to a prism.</p> <p>Three automation modes are available with ATRplus:</p> <ul style="list-style-type: none"> • Manual: no automation and no lock. • Automatic: automatic target aiming to a prism. • LOCK: an already targeted prism is followed automatically.
Telescope camera	The camera is coaxially located in the instruments telescope using the 30x magnification of the telescope optics.
Overview camera	The overview camera is located in the upper part of the telescope housing and has a fixed focus.
PowerSearch	P ower S earch refers to the instrument sensor which enables the automatic rapid finding of a prism.

Term	Description
SmartStation	<p>A Leica Nova TS instrument integrated with an add-on GNSS system, comprising hardware and software components, forms a SmartStation.</p> <p>Components of a SmartStation include a SmartAntenna and a SmartAntenna Adapter.</p> <p>A SmartStation provides an additional instrument setup method for determining instrument station coordinates.</p> <p>The GNSS principles and functionality of a SmartStation derive from the principles and functionality of Leica Viva GNSS instruments.</p>
SmartAntenna	<p>SmartAntenna with integrated Bluetooth is a component of a SmartStation. It can also be used independently on a pole with a CS20 field controller. Models compatible with a MS60/TS60/TM60 instrument are GS16. Where there are differences between the various models they are clearly described.</p>
RadioHandle	<p>A component of remote mode is the RH17/RH18 RadioHandle. It is an instrument carry handle with one or more integrated long range Bluetooth modules with attached antenna.</p>
Communication side cover	<p>Communication side cover with integrated Bluetooth, SD card slot, USB port, WLAN and RadioHandle is standard for a MS60/TS60/TM60 instrument and a component of a SmartStation. In combination with the RH17/RH18 RadioHandle, it is also a component of remote mode.</p>

Instrument Models

Model	TM60 R1000	TM60 I R1000	TS60 I R1000	MS60 R2000
Angle measurement	✓	✓	✓	✓
Distance measurement to prism	✓	✓	✓	✓
Distance measurement to any surface (reflectorless)	✓	✓	✓	✓
Motorised	✓	✓	✓	✓
Automatic Target Aiming (Long Range)	✓	✓	-	-
Automatic Target Aiming (ATRplus)	✓	✓	✓	✓
Lock	-	-	✓	✓
PowerSearch (PS)	-	-	✓	✓
Overview camera	-	✓	✓	✓
Telescope camera	-	✓	✓	✓
Scanning	-	-	-	✓
AutoHeight	-	-	✓	✓

Model	TM60	TM60 I	TS60 I	MS60
	R1000	R1000	R1000	R2000
RS232 and USB interface	✓	✓	✓	✓
SD card and USB stick as storage device	✓	✓	✓	✓
Bluetooth	✓	✓	✓	✓
WLAN	✓	✓	✓	✓
Internal Flash Memory (2 GB)	✓	✓	✓	✓
Hotshoe interface for RadioHandle	✓	✓	✓	✓
Guide Light (EGL)	-	-	✓	✓
Autofocus	-	✓	✓	✓
Uninterruptible electronic power supply due to internal charging functionality	✓	✓	✓	✓

2.2 System Concept

2.2.1 Software Concept

Description

All instruments use the same software concept.

Software for TS models

Software type	Description
TS firmware (xx.fw)	<p>The Leica Captivate software is running on the TS instrument and covers all functions of the instrument.</p> <p>The main applications and languages are integrated into the firmware and cannot be deleted.</p> <p>The languages released with Leica Captivate are included in the firmware file.</p>
Applications (xx.axx)	<p>Many optional survey-specific applications are available for the TS instruments. All applications are included in the Leica Captivate firmware file and can be loaded separately.</p> <p>Some of the applications are activated freely and require no licence key; others require purchasing and are only activated with a licence key.</p> <p>If the licence is not loaded to the instrument, applications requiring a licence key run for a trial period. For a trial run, the Measure&Stakeout licence must be available on the TS.</p>

Software type	Description
Customised applications (xx.axx)	Customised software, specific to user requirements, can be developed using the GeoC++ development kit. Information on the GeoC++ development environment is available on request from a Leica Geosystems representative.

Software upload



Uploading software can take some time. Ensure that the battery is at least 80% full before you start the upload. Do not remove the battery during the upload process.

Software update instructions for all TS models:

1. Download the most recent firmware file from <https://myworld.leica-geosystems.com>. Refer to [Introduction](#).
2. Copy the firmware file into the **System** folder on the memory device.
3. Start the instrument. Select **Settings\Tools\Update software**. Select the firmware file and start the update.
4. When the update is complete, a message appears.

2.2.2

Power Concept

General

Use the batteries, chargers and accessories recommended by Leica Geosystems to ensure the correct functionality of the instrument.

Power options

Model	Power supply
All instrument types	Internally by GEB242 battery, OR Externally by GEV219 cable and GEB373 battery. If an external power supply is connected and the internal battery is inserted, then the external power is used for the standard setting. It is possible to configure the main power source to either internal battery or external power supply. If both power sources are available the internal battery serves as an uninterruptible electronic power supply due to internal charging functionality of the internal battery.
SmartAntenna	Internally via GEB212 battery fitted into the antenna.

2.2.3

Data Storage Concept

Description

Data is stored on a memory device. The memory device can be an SD card or internal memory. For data transfer an USB stick can also be used.

Memory device

Device	Description
SD card	All instruments have an SD card slot fitted as standard. An SD card can be inserted and removed. Available capacity: 1 GB and 8 GB.

Device	Description
USB stick	All instruments have a USB port fitted as standard.
Internal memory	All instruments have an internal memory fitted as standard. Available capacity: 2 GB.

☞ While other SD cards/USB sticks can be used, Leica Geosystems recommends to only use Leica SD cards/USB sticks and is not responsible for data loss or any other error that can occur while using a non-Leica SD card/USB stick.



Unplugging connecting cables or removing the SD card or USB stick during the measurement can cause loss of data. Only remove the SD card or USB stick or unplug connecting cables when the TS instrument is switched off.

Transfer data

Data can be transferred in various ways.



SD cards can directly be used in an OMNI drive as supplied by Leica Geosystems. Other PC card drives can require an adaptor.

2.3

Container Contents

Container for MS60/TS60/TM60 and accessories

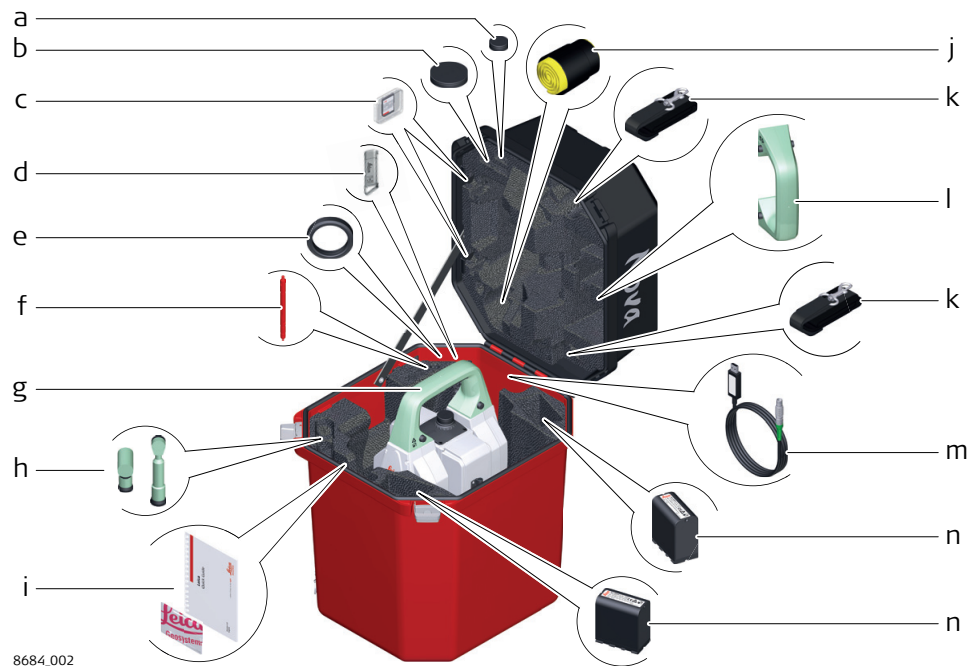

8684.002

- a Cover for eyepiece
- b Cover for objective
- c SD card and cover
- d MS1 industrial 1 GB USB memory stick
- e Counterweight for diagonal eyepiece
- f Stylus
- g Instrument with tribrach and standard handle or RadioHandle
- h GFZ3 or GOK6 diagonal eyepiece
- i Manuals and USB documentation card
- j Protective cover for instrument, sunshade for objective lens and cleaning cloth
- k Container straps
- l Room for standard handle
- m GEV234 Data transfer cable
- n GEB242 battery

**Container for
GS SmartPole/
SmartStation and
accessories -
part 1 of 2**

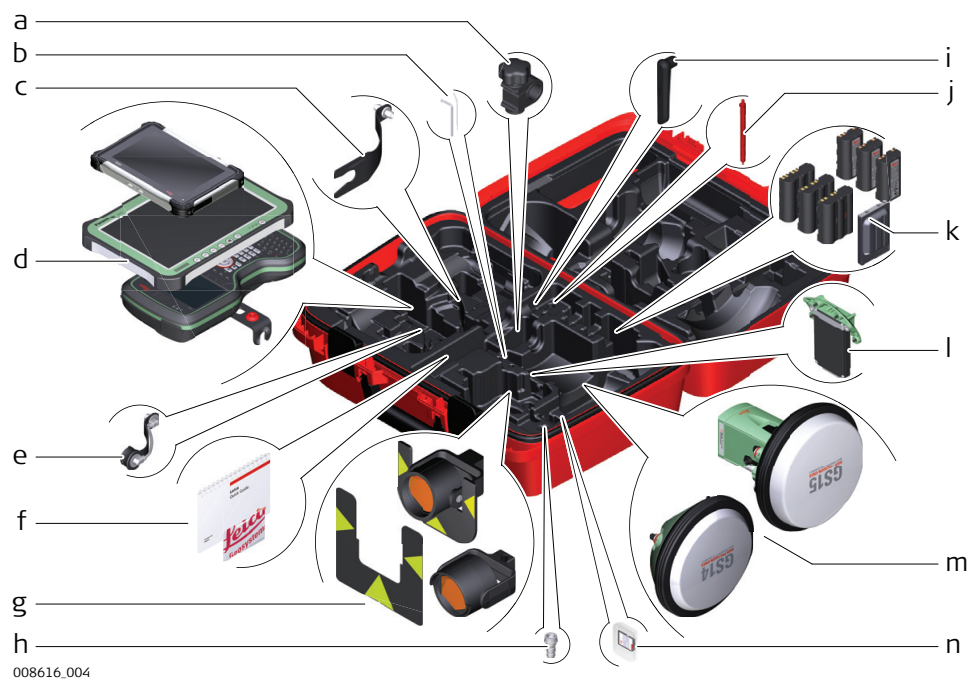

- a GHT63 pole holder clamp
- b Allen key and adjustment tool
- c GAD33 antenna arm
- d CS35/CS30 tablet or CS20 field controller with GHT66 holder
- e GAD108 antenna arm
- f Manuals and USB documentation card
- g GPR121 circular prism PRO or GZT4 target plate for GPH1 and GPH1 prism holder with GPR1 circular prism
- h GAD109 QN-TNC Adapter
- i GAT25 radio antenna
- j Stylus
- k GEB212 or GEB331/GEB333/GEB334 batteries
- l SLXX RTK modem
- m Antenna
- n SD card and cover

- a Manuals and USB documentation card
- b GAT25 radio antenna
- c Mini prism spike
- d GRZ4 or GRZ122 prism
- e SD card and cover
- f Adjustment tool and allen key
- g GRZ101 mini prism and GAD103 adapter
- h GEB331/GEB333/GEB334 battery
- i GHT63 pole holder clamp
- j Tip for mini pole
- k GLI115 clip-on bubble for GLS115 mini prism pole
- l CS30 tablet or CS20 field controller with GHT66 holder
- m Stylus

2.4

Instrument Components

Instrument components part 1 of 2

A TS60/MS60 instrument is shown.

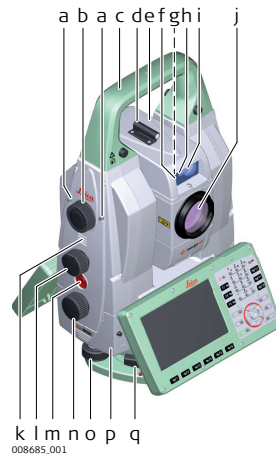

- a Autofocus button
- b Servofocus drive
- c Carry handle
- d Optical sight
- e Telescope with EDM, ATRplus and, if available, camera sensors. For MS60/TS60 also EGL, PS EGL, for MS60/TS60
- f EGL, for MS60/TS60
- g Overview camera, for MS60/TS60/TM60 I
- h PowerSearch, transmitter, for MS60/TS60
- i PowerSearch, receiver, for MS60/TS60
- j Coaxial optics for angle and distance measurements, telescope camera and exit port for visible laser beam for distance measurement
- k Loudspeaker
- l Vertical drive
- m User defined SmartKey
- n Horizontal drive
- o Tribach footscrew
- p SD card and USB stick compartment
- q Tribach securing screw

Instrument components part 2 of 2

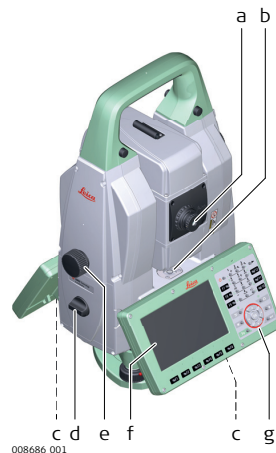

- a Interchangeable eyepiece
- b Circular level
- c Stylus for touch screen
- d Battery compartment
- e Vertical drive
- f Touch screen
- g Keyboard

Communication Side Cover

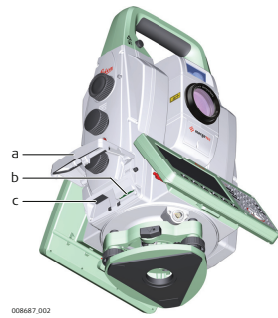

- a Compartment lid
- b SD card port
- c USB host port for USB stick

Instrument components for SmartStation



- a GS16 SmartAntenna
- b GAD110 SmartAntenna Adapter
- c Communication side cover

Instrument components for remote mode



- a RadioHandle
- b Communication side cover

3

User Interface

3.1

Keyboard

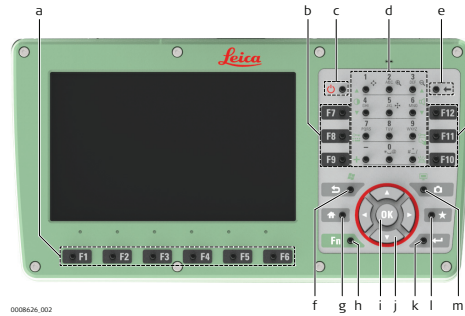

Keyboard
MS60/TS60/TM60

























- a Function keys F1-F6
- b Function keys F7-F12
- c ON/OFF
- d Alphanumeric keys
- e Backspace
- f Esc
- g Home
- h Fn
- i OK
- j Arrow keys
- k Enter
- l Favourites
- m Camera

Keys

Key		Function
Function keys F1 to F6		Correspond to six softkeys that appear on the bottom of the screen when the screen is activated.
Function keys F7 to F12		User definable keys to execute chosen commands or access chosen screens.
Alphanumeric keys		To type letters and numbers.
Camera		To capture an image with the camera.
Esc		Leaves the current screen without storing any changes.
Fn		Switches between the first and second level of function keys.
Enter		Selects the highlighted line and leads to the next logical menu / dialog. Starts the edit mode for editable fields. Opens a selectable list.
ON/OFF		If the instrument is already off: Turns on the instrument when held for 2 s. If the instrument is already on: Turns to Power Options menu when held for 2 s.
Favourites		Goes to a favourites menu.
Home		Switches to the Home Menu. Switches to the Windows EC7 Start Menu when pressing SHIFT at the same time.
Arrow keys		Move the focus on the screen.

Key		Function
OK		Selects the highlighted line and leads to the next logical menu / dialog. Starts the edit mode for editable fields. Opens a selectable list.
Backspace		Deletes the job in the centre of the job carousel.

Key combinations

Key		Function
	+ 	Hold Fn while pressing  . Switch to Windows.
	+ 	Hold Fn while pressing  . Take a screenshot of the current screen.
	+ 1 	Hold Fn while pressing 1 . Increase the screen brightness.
	+ 4 	Hold Fn while pressing 4 . Decrease the screen brightness.
	+ 3 	Hold Fn while pressing 3 . Increase the volume for acoustic warning signals, beeps and keypresses on the instrument.
	+ 6 	Hold Fn while pressing 6 . Decrease the volume for acoustic warning signals, beeps and keypresses on the instrument.
	+ 7 	Hold Fn while pressing 7 . Lock/unlock the keyboard.
	+ 9 	Hold Fn while pressing 9 . Lock/unlock the touch screen.
	+ - 	Hold Fn while pressing +/- . Enter a plus sign instead of a minus sign.
	+ 	Hold Fn while pressing  . Turn the keyboard illumination on/off.

3.2

Keyboard and touch screen

Operating Principles

The user interface is operated either by the keyboard or by the touch screen with supplied stylus. The workflow is the same for keyboard and touch screen entry, the only difference lies in the way information is selected and entered.



Operation by keyboard

Information is selected and entered using the keys.





Operation by touch screen

Information is selected and entered on the screen using the supplied stylus.

Operation	Description
To select an item	Tap on the item.

Operation	Description
To start the edit mode in editable fields	Tap on the editable field.
To highlight an item or parts of it for editing	Drag the supplied stylus from the left to the right.
To accept data entered into an editable field and exit the edit mode	Tap on the screen outside of the editable field.
To open a context-sensitive menu	Tap on the item and hold for 2 s.
To zoom in	Available on CS35/CS30 and other Windows tablets. Tap in the 3D viewer area using two fingers and move them apart. 
To zoom out	Available on CS35/CS30 and other Windows tablets. Tap in the 3D viewer area using two fingers and bring them closer together. 

Operation on CS35/CS30 and other Windows tablets for quick text deletion

Operation	Description
To highlight a whole text for editing	Two options are available: <ul style="list-style-type: none"> • Double-click the text. • Long-press (press-and-hold) on the text.
To delete a whole text	Highlight a whole text for editing. Press the  key on the virtual keyboard.
To delete a whole text and enter new text at the same time	Highlight a whole text for editing. Type the characters for the new text on the virtual board.
To set the cursor at the beginning of a text	Highlight a whole text for editing. Press the  key on the virtual keyboard.
To set the cursor at the end of a text	Highlight a whole text for editing. Press the  key on the virtual keyboard.
To delete the text in the code editable field	Highlight a whole text for editing. Press Ctrl plus  on the virtual keyboard at the same time.

3.3

Autofocus Capability of Telescope Camera

Functionality

The autofocus button is located on the side cover.

Action	Function
Pressing 1x	A single autofocus is executed. The autofocus is related to the selected EDM mode (prism or non-prism measurements).
Pressing 2x	The refocus is executed. Based on the actual focus lense position, a refocus is performed. A refocus does a small movement of the focussing lense to find the best focus position.
Holding for 2 sec	The continuous autofocus is started. By pressing the button again or by turing the servofocus wheel, the continuous autofocus is stopped.

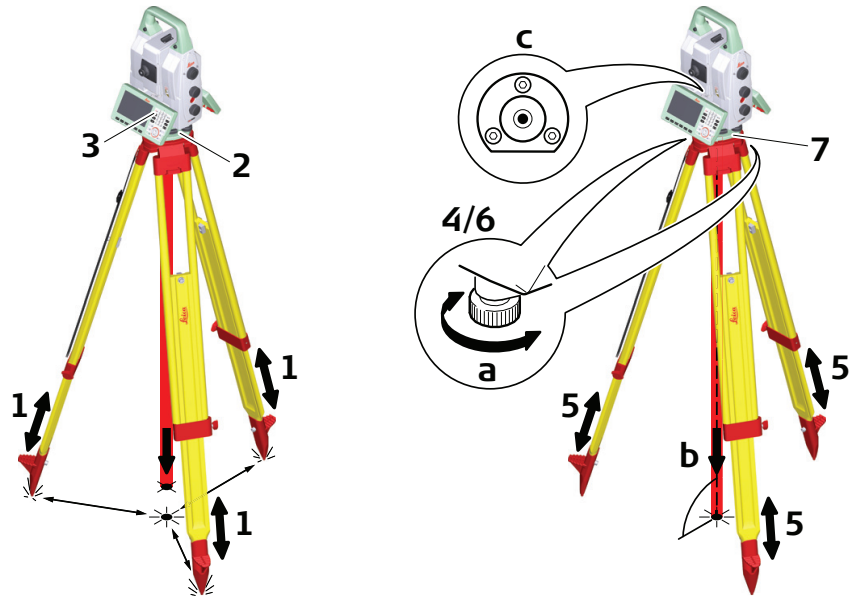
Instrument setup
step-by-step

008690_001



Shield the instrument from direct sunlight and avoid uneven temperatures around the instrument.

1. Extend the tripod legs to allow for a comfortable working posture. Position the tripod above the marked ground point, centring it as good as possible. Ensure that the tripod plate is roughly horizontal.
2. Fasten the tribrach and instrument onto the tripod.
3. Turn on the instrument by pressing . Select **Settings/TS instrument/Level & compensator** to activate the laser plummet and electronic level.
4. Use the tribrach footscrews (a) to centre the plummet (b) above the ground point.
5. Adjust the tripod legs to level the circular level (c).
6. By using the electronic level, turn the tribrach footscrews (a) to level the instrument precisely.
7. Centre the instrument precisely over the ground point (b) by shifting the tribrach on the tripod plate.
8. Repeat steps 6. and 7. until the required accuracy is achieved.



Use the AutoHeight laser plummet for vertically setting up the instrument over a ground point and for measuring the instrument height when setting up the station.

4.2

Setting Up SmartStation

SmartStation Setup step-by-step

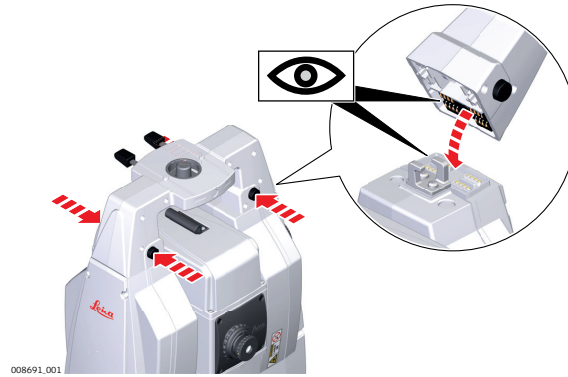

1. Place the GAD110 adapter for the GS16 antenna onto the instrument by simultaneously pressing and holding-in the four push buttons.



Ensure that the interface connection on the underside of the adapter is on the same side as the Communication side cover.



2. Place the GS16 antenna onto the adapter by simultaneously pressing and holding-in the two press clips.

4.3

Setting Up SmartPole

SmartPole Setup using GS16/GS18

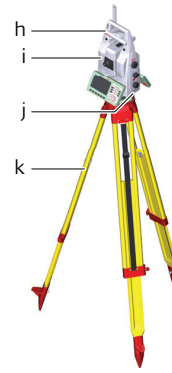
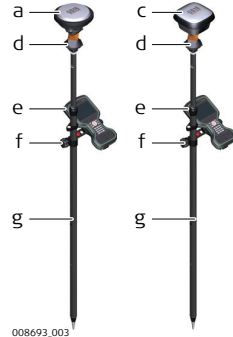

- a GS18 antenna
- b GS16 antenna
- c RTK slot-in device
- d 360° prism
- e Field controller on GHT66 holder
(Alternative, not illustrated: tablet on GHT78 holder)
- f GHT63 clamp
- g GLS31 pole with snap-lock positions
- h RH17/RH18 RadioHandle
- i Instrument
- j Communication side cover, integrated
- k Tripod

4.4

Setting up for Remote Control

4.4.1

Setting up for Remote Control (with the RadioHandle)

Setup for remote control with Radio-Handle

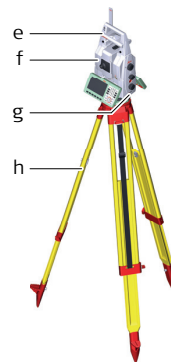

- a 360° prism
- b Prism pole
- c Field controller on GHT66 holder
(Alternative, not illustrated: tablet on GHT78 holder)
- d GHT63 clamp
- e RH17/RH18 RadioHandle
- f Instrument
- g Communication side cover
- h Tripod

4.4.2

Setting up for Remote Control (with the TCPS30)

Setup for remote control with TCPS30

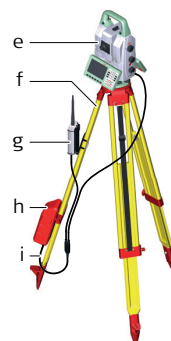

- a 360° prism
- b Prism pole
- c Field controller on GHT66 holder
(Alternative, not illustrated: tablet on GHT78 holder)
- d GHT63 clamp
- e Instrument
- f Tripod
- g TCPS30
- h External battery GEB373
- i Y-cable

Mounting base radio to tripod step-by-step

1. The GHT43 tripod adapter is used to mount the TCPS30 to all Leica standard tripods, and to optimise the radio transmission performance. Attach the TCPS30 to the adapter and then attach the adapter to the tripod leg.

2. Adjust the angle of TCPS30 until it is vertical.

3. Adjust the location of the adapter on the tripod leg so that there are no metallic objects in the horizontal plane around the antenna.
 - ☞ Metallic objects near the antenna disturb radio transmissions.

4. ☞ To achieve the best performance from the TCPS30, mount it in a vertical position on the tripod leg, approximately 30cm from the top.

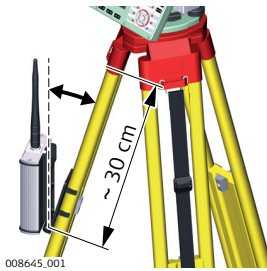

- ☞ If the adapter is no longer able to retain its angle position, the adjustment bolt at the hinge can be tightened slightly.

4.4.3

Fixing the Field Controller to a Holder and Pole

Components of the GHT66 holder

The GHT66 holder consists of the following components:

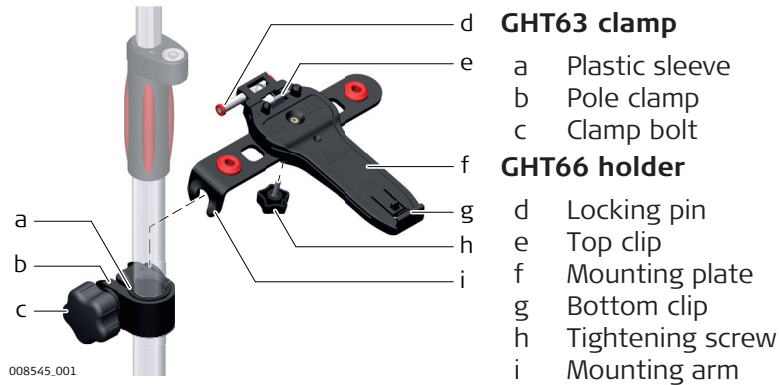

Fixing the field controller and GHT66 to a pole step-by-step

- ☞ For an aluminium pole, fit the plastic sleeve to the pole clamp.

1. Insert the pole into the clamp hole.

2. Attach the holder to the clamp using the clamp bolt.

3. Adjust the angle and the height of the holder on the pole to a comfortable position.

4. Tighten the clamp with the clamp bolt.

5. Before placing the CS field controller onto the mounting plate, ensure that the locking pin is put into the unlocked position. To unlock the locking pin, push the locking pin to the left.

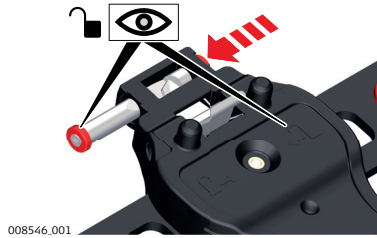

6. Hold the CS field controller above the holder and lower the end of the CS field controller into the mounting plate.
7. Apply slight pressure in a downward direction and then lower the top part of the CS field controller until the unit is clicked into the holder. The guides of the mounting plate aid in this action.

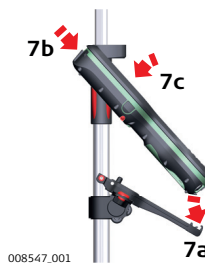

8. After the CS field controller is placed onto the mounting plate, ensure that the locking pin is put into the locked position. To lock the locking pin, push the locking pin to the right.

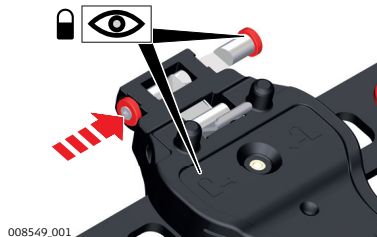

Detaching the field controller from a pole step-by-step

1. Unlock the locking pin by pushing the locking pin to the left of the mounting plate.
2. Place your palm over the top of the field controller.
3. While in this position, lift the top of the field controller from the holder.

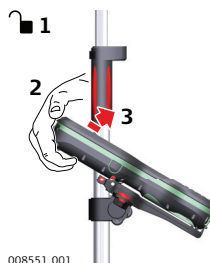

4.4.4

Fixing the CS35 Tablet to a Holder and Pole

Components of GHT63 clamp and GHT78 holder

For fixing the CS35 tablet to a pole you need the following components:

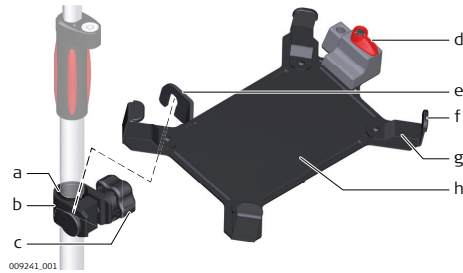

GHT63 clamp

- a Plastic sleeve
- b Pole clamp
- c Clamp bolt

GHT78 holder

- d Locking lever
- e Mounting arm
- f Mounting brackets
- g Removable inserts
- h Mounting plate

Fixing the CS35 tablet and GHT78 to a pole step-by-step

➡ For an aluminium pole, fit the plastic sleeve to the pole clamp.

➡ If the 833343 hand strap with high corner guards is attached to the tablet, remove the inserts from the mounting brackets before fixing the tablet to the mounting plate. To untighten the screws of the removable inserts, use a 2.5 mm allen key.

1. Insert the pole into the clamp hole.
2. Attach the holder to the clamp using the clamp bolt.
3. Adjust the angle and the height of the holder on the pole to a comfortable position.
4. Tighten the clamp with the clamp bolt.

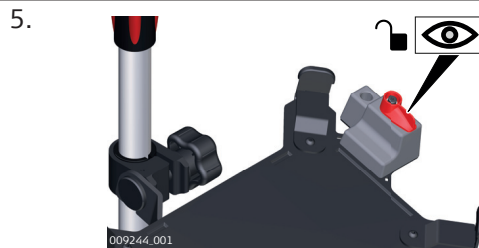

Before placing the CS35 tablet onto the mounting plate, ensure that the locking lever is set to the unlocked position (see illustration).

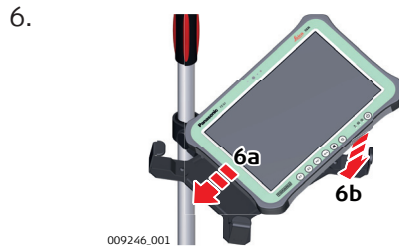

Lower the left side of the tablet and slide it from right to left into the mounting brackets of the holder.

7.

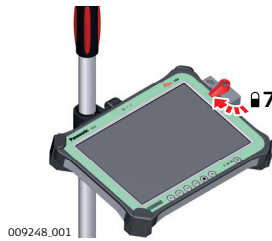

After placing the tablet onto the mounting plate, set the locking lever to the locked position (see illustration).

Detaching the tablet from the holder/pole step-by-step

1.

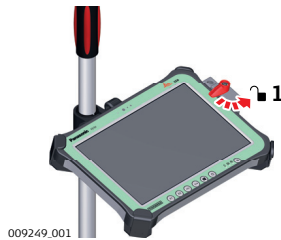

Set the locking lever of the GHT78 holder to the unlocked position.

2.

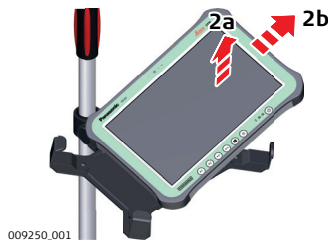

Lift the right side of the tablet and slide the tablet to the right and out of the holder.

4.5

Connecting to a Personal Computer

Description

Windows Mobile Device Center for PC with Windows 7/Windows 8/Windows 10 operating system is the synchronization software for Windows mobile-based pocket PC. WMDC enables a PC and a Windows mobile-based pocket PC to communicate.

Leica USB drivers support Windows 7, Windows 8 (8.1) and Windows 10 operating systems.

Cables

Leica USB drivers support:

Name	Description
GEV223	USB data cable, 1.8 m, connects instrument to Mini-USB to USB
GEV234	USB data cable, 1.65 m, connects CS to GS or CS to PC (USB)
GEV261	Y-cable, 1.8 m, connects instrument to PC – battery

Uninstalling the previous drivers



Skip the following steps if you have never installed Leica USB drivers before.

If older drivers were previously installed on the PC, follow the instructions to uninstall the drivers prior the installation of the new drivers.

1. Connect your instrument to the PC via cable.

2. On your PC, select to **Control Panel > Device Manager**.

3. In **Network Adapters**, right-click on **Remote NDIS based LGS...**

4. Click on **Uninstall**.

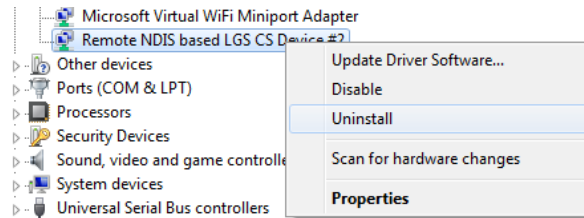

5. Set **Delete the driver...** as checked. Press **OK**.



Install Leica USB drivers

1. Start the PC.

2. Run the **Setup_Leica_USB_XXbit.exe** to install the drivers necessary for Leica devices. Depending on the version (32bit or 64bit) of the operating system on your PC, you have to select between the three setup files following:
 - Setup_Leica_USB_32bit.exe
 - Setup_Leica_USB_64bit.exe
 - Setup_Leica_USB_64bit_itanium.exe
 - ☞ To check the version of your operating system, go to **Control Panel > System > System type**.
 - ☞ The setup requires administrative privileges.
 - ☞ The setup has to be run only once for all Leica devices.

3. The **Welcome to InstallShield Wizard for Leica GS, TS/TM/MS, CS and GR USB drivers** window appears.
 - ☞ Ensure that all Leica devices are disconnected from your PC before you continue!

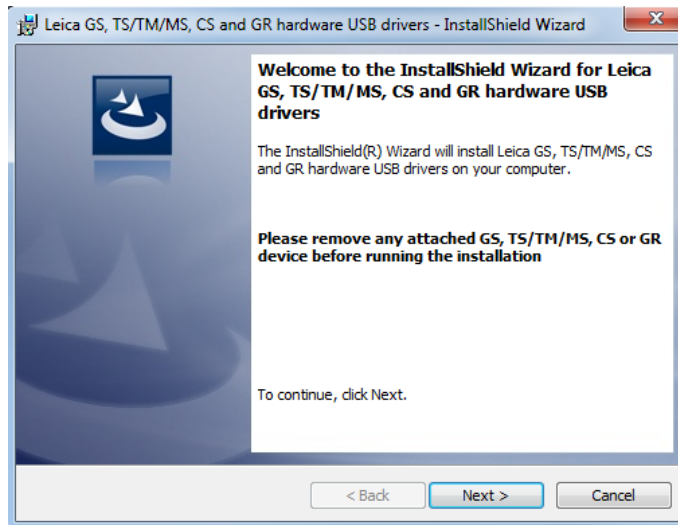

4. Click **Next>**.
5. The **Ready to Install the Program** window appears.

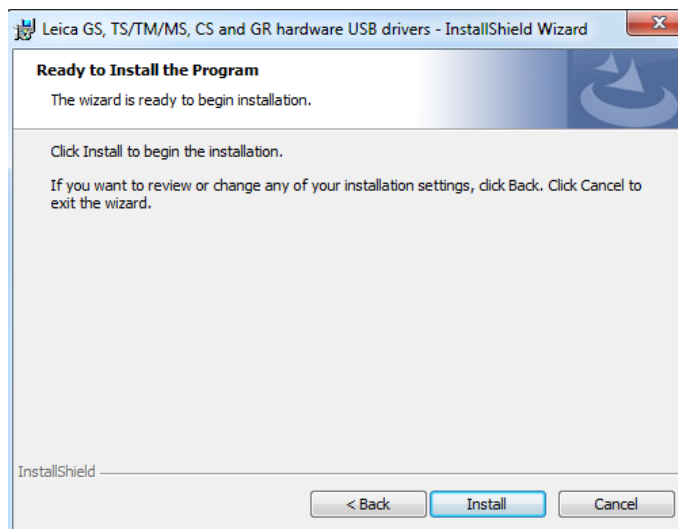

6. Click **Install**. The drivers will be installed on your PC.
7. The **InstallShield Wizard Completed** window appears.
8. Click **Finish** to exit the wizard.

Connect to PC via USB cable step-by-step

1. Start the PC.
2. Plug the cable into the instrument.
3. Turn on the instrument.
4. Plug the cable into the USB port of the PC.
5. Press the Windows Start button at the bottom left corner of the screen.
6. Type the IP address of the device into the search field.
 - \\192.168.254.1\ for field controller
7. Press **Enter**.

A file browser opens. You can now browse within the folders on the instrument.

4.6

Power Functions

Turning the instrument on

Press and hold power key (⏻) for 2s.



The instrument must have a power supply.

Turning the instrument off

Press and hold power key (⏻) for 2 s.



The instrument must be on.



For instruments setup in permanent installations with external power sources, for example monitoring, ensure external power remains available until the instrument has successfully completed the power down process.

Power options menu

Press and hold power key (⏻) for 2 s to open **Power Options** menu.



Instrument must be on.

Option	Description
Turn off	Turn TS instrument off.
Stand-by	Put TS instrument into stand-by mode.  In stand-by mode, the TS instrument shuts down and reduces power consumption. Rebooting from stand-by mode is quicker than a cold start after turning off.
Reset...	Performs one of the following options: <ul style="list-style-type: none">• Restart (restarts Windows EC7)• Reset Windows EC7 (resets Windows EC7 and communication settings to factory defaults)• Reset installed software (resets settings of all installed software)• Reset Windows EC7 and installed software (resets Windows EC7 and settings of all installed software)

4.7

Batteries

4.7.1

Operating Principles

First-time use/ charging batteries

- The battery must be charged before using it the first time, because it is delivered with an energy content as low as possible or might be in sleep mode.
- The permissible temperature range for charging is from 0 °C to +40 °C/ +32 °F to +104 °F. For optimal charging, we recommend charging the batteries at a low ambient temperature of +10 °C to +20 °C/+50 °F to +68 °F if possible
- It is normal for the battery to become warm during charging. Using the chargers recommended by Leica Geosystems, it is not possible to charge the battery once the temperature is too high
- For new batteries or batteries that have been stored for a long time (> three months), it is effectual to make a discharge/charge cycle
- For Li-Ion batteries, a single discharge/charge cycle is sufficient. We recommend carrying out the process when the battery capacity indicated on the charger or on a Leica Geosystems product deviates significantly from the actual battery capacity available.

Operation/discharging

- The batteries can be operated from -20 °C to +55 °C/-4 °F to +131 °F.
- Low operating temperatures reduce the capacity that can be drawn; high operating temperatures reduce the service life of the battery.

4.7.2

Battery for the TS Instrument

Change battery step- by-step

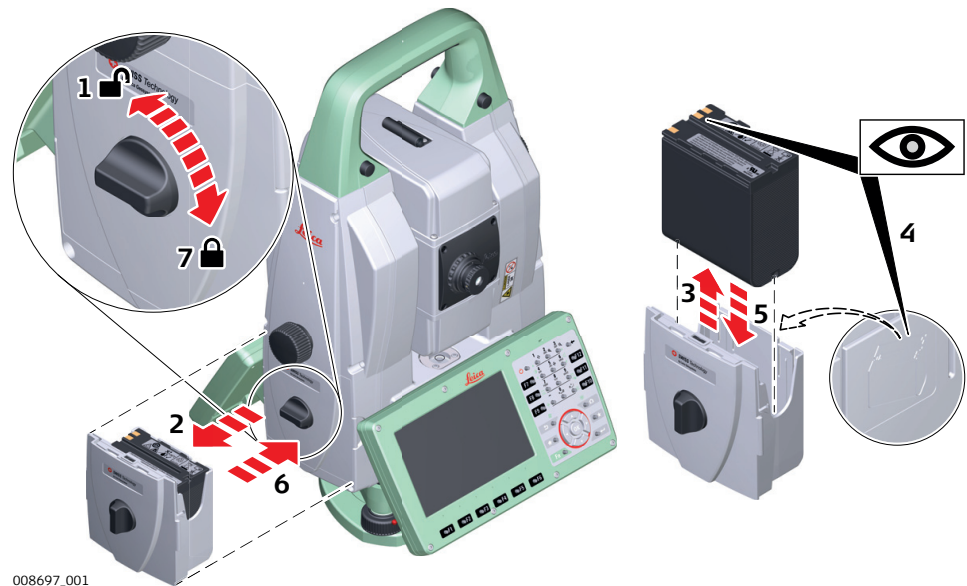

1. Face the instrument so that the vertical drive screw is on the left. The battery compartment is below the vertical drive. Turn the knob to the vertical position, opening the lid of the battery compartment.
2. Pull out the battery housing.
3. Pull the battery from the battery housing.
4. A pictogram of the battery is displayed inside the battery housing. This pictogram is a visual aid to assist in placing the battery correctly.

5. Place the battery into the battery housing, ensuring that the contacts are facing outward. Click the battery into position.
6. Place the battery housing into the battery compartment. Push the battery housing in until it fits completely into the battery compartment.
7. Turn the knob to lock the battery compartment. Ensure that the knob is returned to its original horizontal position.

4.8

Working with the Memory Device



- Keep the card dry.
- Use it only within the specified temperature range.
- Do not bend the card.
- Protect the card from direct impacts.



Failure to follow these instructions could result in data loss and/or permanent damage to the card.

Insert and remove an SD card step-by-step

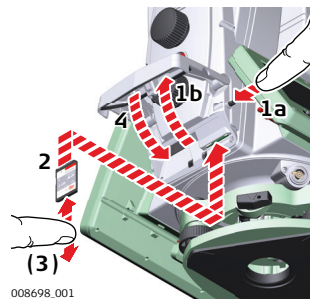

The SD card is inserted into a slot inside the Communication side cover of the instrument.

1. Press the button on the side of the Communication side cover to unlock the communication compartment.



The lid opens automatically.

2. To insert the SD card, slide it firmly into the SD slot until it clicks into position.



The card must be held with the contacts at the top and facing toward the instrument.



Do not force the card into the slot.

3. To remove the SD card, gently press on the top of the card to release it from the slot.

4. Close the lid by pushing the door down. Push the door on the marked part in the middle of the door.

Insert and remove a USB stick step-by-step

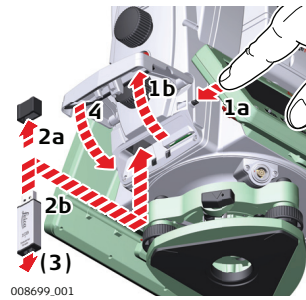

The USB stick is inserted into the USB host port inside the Communication side cover of the instrument.

1. Press the button on the side of the Communication side cover to unlock the communication compartment.



The lid opens automatically.

2. To insert the USB stick, remove the cap of the USB stick. Hold the USB stick with the Leica logo facing you and slide it firmly into the USB host port until it clicks into position.



Do not force the USB stick into the port.

3. To remove the USB stick, slide the USB stick out of the port.
4. Close the lid by pushing the door down. Push the door on the marked part in the middle of the door.

4.9

LED Indicators

LED indicators on RH17 RadioHandle

Description

The RadioHandle has Light Emitting Diode (LED) indicators. They indicate the basic RadioHandle status.

Diagram of the LED Indicators

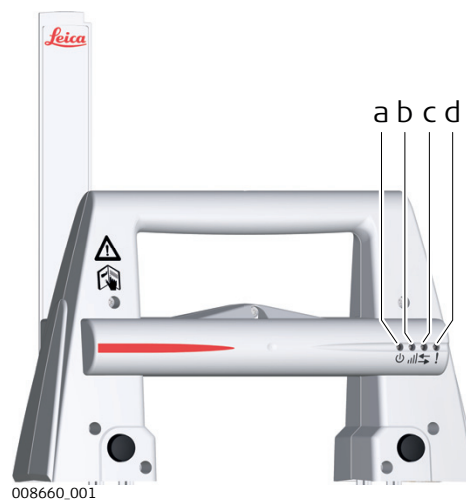

- a Power LED
- b Link LED
- c Data Transfer LED
- d Mode LED

Description of the LED Indicators

IF the	is	THEN
Power LED	off	power is off.
	green	power is on.

IF the	is	THEN
Link LED	off	no radio link to field controller.
	red	radio link to field controller.
Data Transfer LED	off	no data transfer to/from field controller.
	green or green flashing	data transfer to/from field controller.
Mode LED	off	data mode.
	red	configuration mode.

LED indicators on RH18 RadioHandle

Description

The RadioHandle has Light Emitting Diode (LED) indicators. They indicate the basic RadioHandle status.

Diagram of the LED Indicators

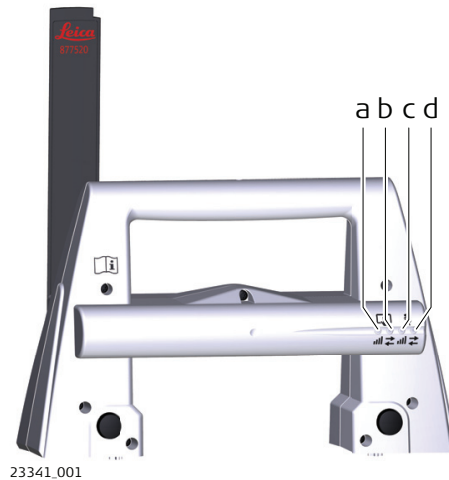

- a CS Link LED
- b CS Data Transfer LED
- c AP Link LED
- d AP Data Transfer LED

Description of the LED Indicators

IF the	is	THEN
CS Link LED and AP Link LED	off	power is off.
CS Link LED	green	no radio link to field controller.
	blue	radio link to field controller.
CS Data Transfer LED	off	no data transfer to/from field controller.
	green or green flashing	data transfer to/from field controller.
	red	configuration mode.
AP Link LED	green	no radio link to AutoPole.
	blue	radio link to AutoPole.
AP Data Transfer LED	off	no data transfer to/from AutoPole.

IF the	is	THEN
	green or green flashing	data transfer to/from AutoPole.
	red	synchronisation mode.

4.10

Guidelines for Correct Results

Distance measurement

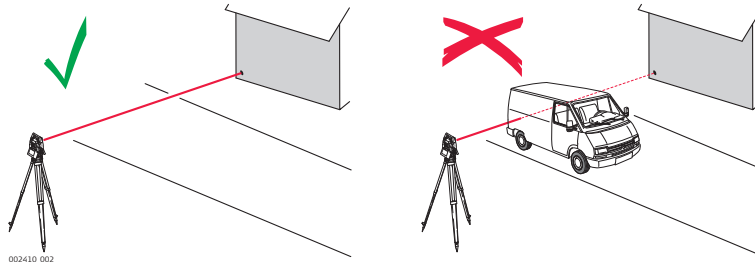

When measurements are being made using the red laser EDM, the results can be influenced by objects passing between the EDM and the intended target surface. This occurs because reflectorless measurements are made to the first surface returning sufficient energy to allow the measurement to take place. For example, if the intended target surface is the surface of a building, but a vehicle passes between the EDM and the target surface as the measurement is triggered, the measurement may be made to the side of the vehicle. The result is the distance to the vehicle, not to the surface of the building.

If using the long range measurement mode (> 1000 m, > 3300 ft, available on TS60/TM60) to prisms, and an object passes within 30 m of the EDM as the measurement is triggered, the distance measurement may be similarly effected due to the strength of the laser signal.



Very short distances can also be measured reflectorless in **Prism** mode to well reflecting natural targets. The distances are corrected with the additive constant defined for the active reflector.

WARNING

Due to laser safety regulations and measuring accuracy, using the Long Range Reflectorless EDM is only allowed to prisms that are more than 1000m (3300ft) away.



Accurate measurements to prisms should be made in **Prism** mode.



When a distance measurement is triggered, the EDM measures to the object which is in the beam path at that moment. If a temporary obstruction, for example a passing vehicle, heavy rain, fog or snow is between the instrument and the point to be measured, the EDM may measure to the obstruction.



Do not measure with two instruments to the same target simultaneously to avoid getting mixed return signals.

ATRplus/Lock

Instruments equipped with an ATRplus sensor permit automatic angle and distance measurements to prisms. The prism is sighted with the optical sight. After initiating a distance measurement, the instrument sights the prism centre automatically. Vertical and horizontal angles and the distance are measured to the centre of the prism. The lock mode enables the instrument to follow a moving prism.



As with all other instrument errors, the collimation error of the automatic aiming must be redetermined periodically. Refer to [5 Check & Adjust](#) about checking and adjusting instruments.



When a measurement is triggered while the prism is still moving, distance and angle measurements may not be made for the same position and coordinates may vary.



If the prism location is changed too quickly, the target may be lost. Make sure that the speed does not exceed the figure given in the technical data.

Motorised positioning

Unstable instrument setup conditions or small vibrations of the instrument resulting from heavy traffic or construction activities in the vicinity of the instrument may lead to an abandonment of the instrument's positioning before the final position is reached. Ensure that the instrument setup is stable, especially if steep sightings are necessary. If an incomplete positioning is indicated check the position deviation and repeat the according positioning command.

5

Check & Adjust

5.1

Overview

Description

Leica Geosystems instruments are manufactured, assembled and adjusted to the best possible quality. Quick temperature changes, shock or stress can cause deviations and decrease the instrument accuracy. It is therefore recommended to check and adjust the instrument from time to time. This check and adjust can be done in the field by running through specific measurement procedures. The procedures are guided and must be followed carefully and precisely as described in the following chapters. Some other instrument errors and mechanical parts can be adjusted mechanically.

Electronic adjustment

The following instrument errors can be checked and adjusted electronically:

Instrument error	Description
l, t	Compensator longitudinal and transversal index errors
i	Vertical index error, related to the standing axis
c	Horizontal collimation error, also called line of sight error
a	Tilting axis error
ATRplus	ATRplus zero point error for Hz and V
Telescope camera	Telescope camera zero point error, relation between principal point of telescope camera and crosshair in telescope in Hz and V - option

If the compensator and the horizontal corrections are activated in the instrument configuration, every angle measured in the daily work is corrected automatically. Check whether the tilt correction and the horizontal correction are turned on.

The results are displayed as errors but used with the opposite sign as corrections when applied to measurements.

Mechanical adjustment

The following instrument parts can be adjusted mechanically:

- Circular level on instrument and tribrach
- Optical plummet - option on tribrach
- Allen screws on tripod

Precise measurements

To get precise measurements in the daily work, it is important:

- To check and adjust the instrument from time to time.
- To take high precision measurements during the check and adjust procedures.
- To measure targets in two faces. Some of the instrument errors are eliminated by averaging the angles from both faces.



During the manufacturing process, the instrument errors are carefully determined and set to zero. As mentioned above, these errors can change and it is highly recommended to redetermine them in the following situations:

- Before the first use
- Before every high precision survey
- After rough or long transportation
- After long working periods
- After long storage periods
- If the temperature difference between current environment and the temperature at the last calibration is more than 20 °C

Summary of errors to be adjusted electronically

Instrument error	Effects Hz	Effects V	Elimination with two face measurement	Automatically corrected with proper adjustment
c - Line of sight error	✓	-	✓	✓
a - Tilting axis error	✓	-	✓	✓
l - Compensator index error	-	✓	✓	✓
t - Compensator index error	✓	-	✓	✓
i - Vertical index error	-	✓	✓	✓
ATRplus Collimation error	✓	✓	-	✓
Co-axial camera collimation error	✓	✓	✓	✓

5.2

Preparation

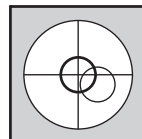

Before determining the instrument errors, the instrument has to be levelled using the electronic level. The tribrach, the tripod and the underground should be stable and secure from vibrations or other disturbances.



The instrument should be protected from direct sunlight to avoid thermal warming. It is also recommended to avoid strong heat shimmer and air turbulence. The best conditions are early in the morning or with overcast sky.



Before starting to work, the instrument has to become acclimatised to the ambient temperature. Take at least 15 minutes into account or approximately 2 minutes per °C of temperature difference from storage to working environment.



Precise manual aiming procedures are the base for a fitting determination of the instrument error corrections. Take the time to aim accurately and measure with highest precision. For consistent Check & Adjust results on job sites with several instruments, the procedures should be performed by the same operator on all instruments.



Even after adjustment of the ATRplus, the crosshairs may not be positioned exactly on the centre of the prism after an ATRplus measurement has been completed. This outcome is a normal effect. To speed up the ATRplus measurement, the telescope is normally not positioned exactly on the centre of the prism. These small deviations ATRplus offsets, are calculated individually for each measurement and corrected electronically. This means that the horizontal and vertical angles are corrected twice: first by the determined ATRplus errors for Hz and V, and then by the individual small deviations of the current aiming.

Next step

IF the task is to	THEN
adjust a combination of instrument errors	Refer to 5.3 Combined Adjustment (l, t, i, c, ATRplus and Telescope Camera) .
adjust the tilting axis	Refer to 5.4 Tilting Axis Adjustment (a) .
adjust the circular level	Refer to 5.5 Adjusting the Circular Level of the Instrument and Tribrach .
adjust the laser/optical plummet	Refer to 5.7 Inspecting the Laser Plummet of the Instrument .
adjust the tripod	Refer to 5.8 Servicing the Tripod .

5.3

Combined Adjustment (l, t, i, c, ATRplus and Telescope Camera)

Description

The combined adjustment procedure determines the following instrument errors in one process:

Instrument error	Description
l, t	Compensator longitudinal and transversal index errors
i	Vertical index error, related to the standing axis
c	Horizontal collimation error, also called line of sight error
ATRplus Hz	ATRplus zero point error for horizontal angle
ATRplus V	ATRplus zero point error for vertical angle
Telescope camera Hz	Telescope camera zero point error for horizontal angle - option
Telescope camera V	Telescope camera zero point error for vertical angle - option

Combined adjustment procedure step-by-step

The following table explains the most common settings.

1. **Leica Captivate - Home: Settings\TS instrument\Check & adjust**

2. **Check & Adjust**

Select the option: **Check & adjust the compensator, index error, line of sight error, automatic target aiming & telescope camera**

3. **Next**

4. **Face I measurement**

If **Calibrate the automatic target aiming** is checked and an ATRplus is available, the adjustment will include the determination of the ATRplus Hz and V adjustment errors.

If **Calibrate the telescope camera** is checked and a telescope camera is available, the adjustment includes the determination of the telescope camera zero point.

☞ Use a clean Leica standard prism as the target. Do not use a 360° prism.

☞ Calibration distances of the automatic target aiming require a precise manual aiming and should be aligned with typical measurement distances on the job site.

5. Aim the telescope accurately at a target at about 100 m distance. The target must be positioned within $\pm 9^\circ/\pm 10$ gon of the horizontal plane.

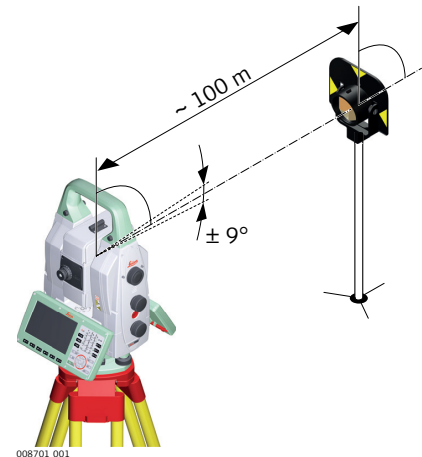

6. Aim precisely at the center of the prism and press **Measure** to continue to the next screen. If **Calibrate the telescope camera** has been checked, aim at the same target accurately with the telescope camera using the view finder and the digital crosshair on the display. **Measure** to measure and to continue to the next screen.

☞ The fine pointing has to be performed manually in both faces.

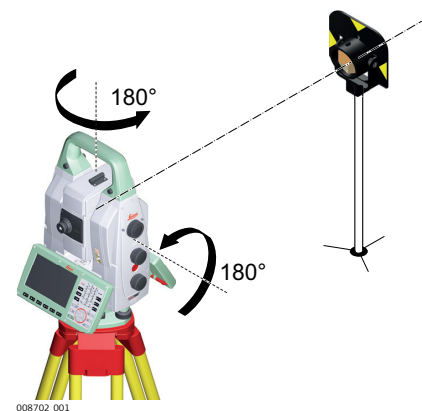

7. **Face II measurement**
Measure to measure the same target in the other face.
 If **Calibrate the telescope camera** has been checked, aim at the same target accurately with the telescope camera using the view finder and the digital crosshair on the display. **Measure** measure to the target and to calculate the instrument errors.

- ☞ If one or more errors are bigger than the predefined limits, the procedure must be repeated. All measurements of the current run are rejected and none of them is averaged with the results from previous runs.

8. Adjustment Status
Number of measurements: Shows the number of runs completed. One run consists of a measurement in face I and face II.
I Component quality (1σ) and similar lines show the standard deviations of the determined adjustment errors. The standard deviations can be calculated from the second run onwards.

- ☞ Achieved adjustment qualities should be aligned with the expected measurement accuracies. In order to leverage aiming errors it is advisable to measure at least three runs.

9. **Next** to continue with the check & adjust procedure.

10. Follow the proposal **Add another calibration loop** until three runs have been measured. **Next** and continue with step 4.
 OR
 Select **Finish the calibration & store the results** to finish the calibration process. **Next** to view the adjustment results.

11. Select **Finish** to accept the results. No more runs can be added later.
 OR
 Select **Redo** to decline all measurements and to repeat all calibration runs.
 OR
Back returns to the previous screen.

Next step

IF the results are	THEN
to be stored	If the Use status is set to Yes, Next overwrites the old adjustment errors with the new ones.
to be determined again	Redo rejects all new determined adjustment errors and repeats the whole procedure. Refer to paragraph Combined adjustment procedure step-by-step .

5.4

Tilting Axis Adjustment (a)

Description

This adjustment procedure determines the following instrument error:

Instrument error	Description
a	Tilting-axis error

Determination of tilting axis error step-by-step

The following table explains the most common settings.

- ☞ Determine the horizontal collimation error (c) before starting this procedure.

1. **Leica Captivate - Home: Settings\TS instrument\Check & adjust**

2. **Check & Adjust**

Select the option: **Check & adjust the tilting axis**

3. **Face I measurement**

Aim the telescope accurately at a target at about 100 m distance (or at least 20 m). The target must be positioned at least 27°/30 gon above or beneath the horizontal plane.

- ☞ Calibration distances of the automatic target aiming require a precise manual aiming and should be aligned with typical measurement distances on the job site.

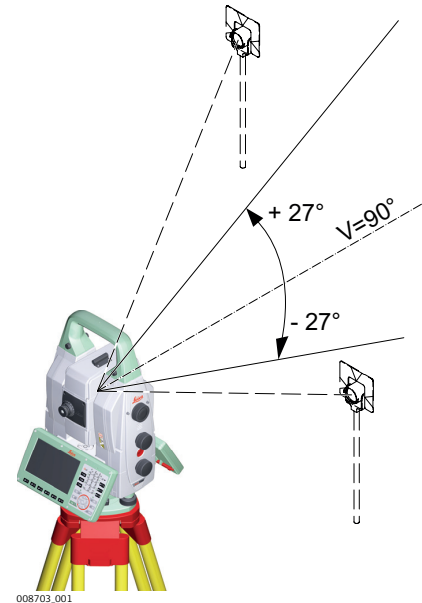

-
4. Aim precisely at the center of the prism and press **Measure** to continue to the next screen.

- ☞ The fine pointing must be performed manually in both faces.

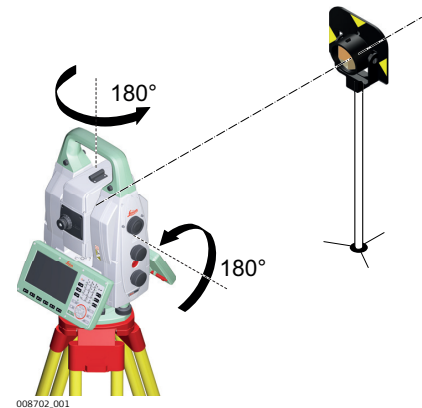

5. **Face II measurement**

Measure to measure the same target in the other face and to calculate the tilting axis error.

- ☞ If the error is bigger than the predefined limit, the procedure must be repeated. The tilting axis measurements of the current run are then rejected and not averaged with the results from previous runs.
-

6. Adjustment Status

Number of measurements: Shows the number of runs completed. One run consists of a measurement in face I and face II.

a T-axis quality (1 σ): Shows the standard deviation of the determined tilting axis error. The standard deviation can be calculated from the second run onwards.

- ☞ Achieved adjustment qualities should be aligned with the expected measurement accuracies. In order to leverage aiming errors it is advisable to measure at least three runs.
-

7. **Next** to continue with the check & adjust procedure.

8. Follow the proposal **Add another calibration loop** until three runs have been measured. **Next** and continue with step 3.
OR
Select **Finish the calibration & store the results** to finish the calibration process. No more runs can be added later. **Next** to view the adjustment results.

9. Select **Finish** to accept the results. No more runs can be added later.
OR
Select **Redo** to decline all measurements and to repeat all calibration runs.

Next step

IF the results are	THEN
to be stored	Next overwrites the old tilting axis error with the new one.
to be determined again	Redo rejects the new determined tilting axis error and repeats the whole procedure. Refer to paragraph Tilting Axis Adjustment (a) .

5.5

Adjusting the Circular Level of the Instrument and Tribrach

Adjusting the circular level step-by-step

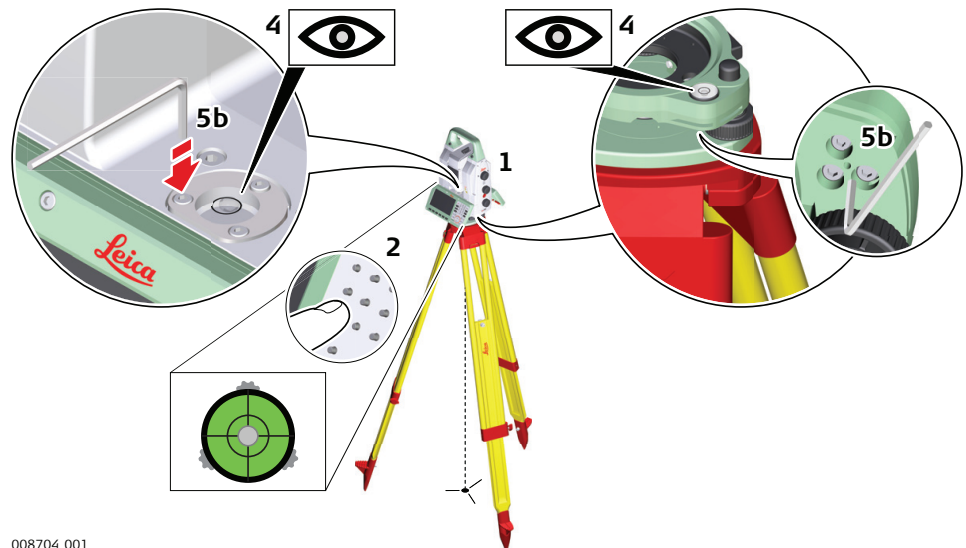

008704.001

1. Place and secure the instrument into the tribrach and onto a tripod.

2. Using the tribrach footscrews, level the instrument with the electronic level.

3. Select **Settings\TS instrument\Level & compensator** to access the **Level & Compensator** screen.

4. Check the position of the circular level on the instrument and tribrach.

5.
 - a If both circular levels are centred, no adjustments are necessary

- b If one or both circular levels are not centred, adjust as follows:

Instrument: If it extends beyond the circle, use the supplied allen key to centre it with the adjustment screws. Turn the instrument by 200 gon (180°). Repeat the adjustment procedure if the circular level does not stay centred.

Tribrach: If it extends beyond the circle, use the supplied allen key to centre it with the adjustment screws.



After the adjustments, all adjusting screws must have the same tightening tension and no adjusting screw should be loose.

5.6

Adjusting the Circular Level of the Prism Pole

Adjusting the circular level step-by-step

1. Suspend a plumb line.
2. Use a pole bipod, to align the prism pole parallel to the plumb line.
3. Check the position of the circular level on the prism pole.
4.
 - a If the circular level is centred, no adjustment is necessary.
 - b If the circular level is not centred, use an allen key to centre it with the adjustment screws.

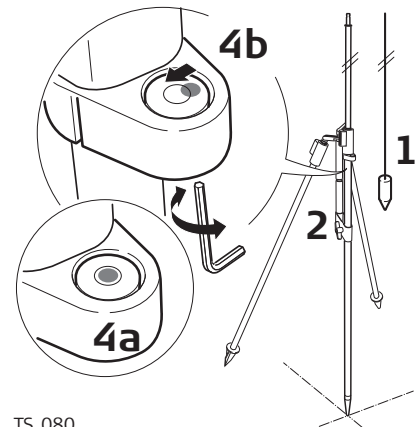

After the adjustments, all adjusting screws must have the same tightening tension and no adjusting screw should be loose.

5.7

Inspecting the Laser Plummet of the Instrument



The laser plummet is located in the vertical axis of the instrument. Under normal conditions of use, the laser plummet does not need adjusting. If an adjustment is necessary due to external influences, return the instrument to any Leica Geosystems authorised service workshop.

Inspecting the laser plummet step-by-step

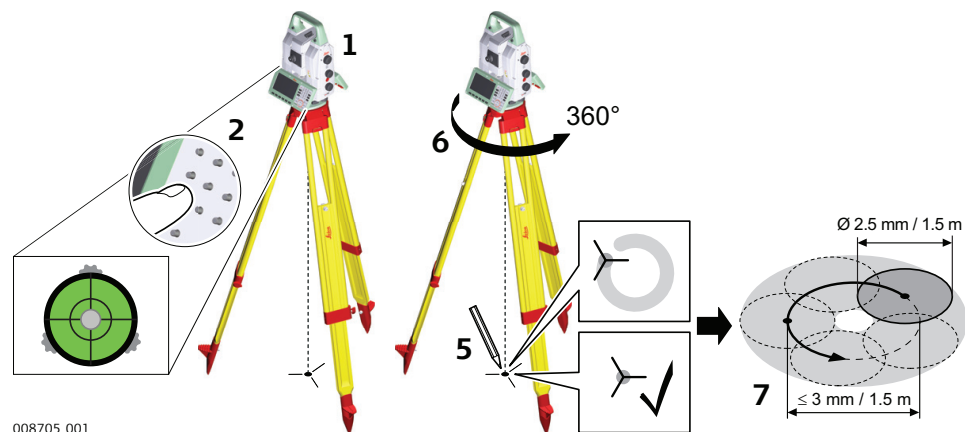

The following table explains the most common settings.

1. Place and secure the instrument into the tribrach and onto a tripod.
 2. Using the tribrach footscrews, level the instrument with the electronic level.
 3. Select **Settings\TS instrument\Level & compensator** to access the **Level & Compensator** screen.
 4. The laser plummet is switched on when the **Level & Compensator** screen is entered. Adjust the laser plummet intensity. Inspection of the laser plummet should be carried out on a bright, smooth and horizontal surface, like a sheet of paper.
 5. Mark the centre of the red dot on the ground.
 6. Turn the instrument through 360° slowly, carefully observing the movement of the red laser dot.
-  The maximum diameter of the circular movement described by the centre of the laser point must not exceed 3 mm at a distance of 1.5 m.
7. If the centre of the laser dot describes a perceptible circular movement, or moves more than 3 mm away from the point which was first marked, an adjustment may be required. Inform your nearest Leica Geosystems authorised service workshop. Depending on brightness and surface, the diameter of the laser dot can vary. At 1.5 m, it is about 2.5 mm.

5.8

Servicing the Tripod

Servicing the tripod step-by-step

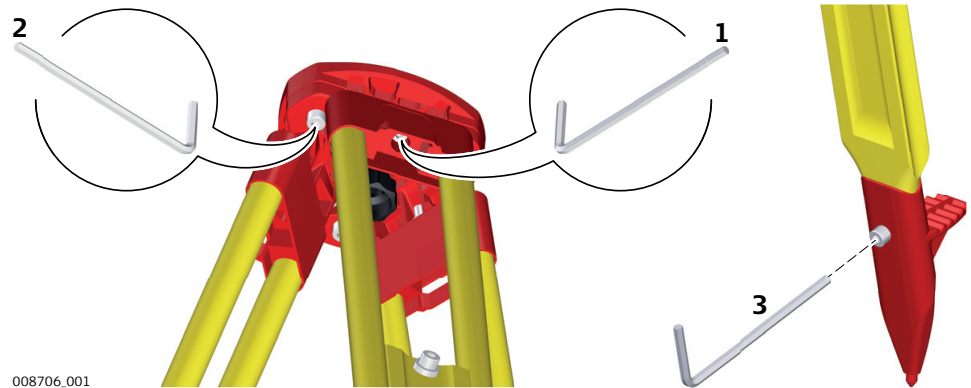

The following table explains the most common settings.

-  The connections between metal and timber components must always be firm and tight.

1. Tighten the leg cap screws moderately, with the supplied Allen key.
2. Tighten the articulated joints on the tripod head enough to keep the tripod legs open when lifting the tripod off the ground.
3. Tighten the Allen screws of the tripod legs.

6 Care and Transport

6.1 Transport

Transport in the field	<p>When transporting the equipment in the field, always make sure that you</p> <ul style="list-style-type: none">• either carry the product in its original container,• or carry the tripod with its legs splayed across your shoulder, keeping the attached product upright.
Transport in a road vehicle	<p>Never carry the product loose in a road vehicle, as it can be affected by shock and vibration. Always carry the product in its container and secure it.</p> <p>For products for which no container is available use the original packaging or its equivalent.</p>
Shipping	<p>When transporting the product by rail, air or sea, always use the complete original Leica Geosystems packaging, container and cardboard box, or its equivalent, to protect against shock and vibration.</p>
Shipping, transport of batteries	<p>When transporting or shipping batteries, the person responsible for the product must ensure that the applicable national and international rules and regulations are observed. Before transportation or shipping, contact your local passenger or freight transport company.</p>
Field adjustment	<p>Exposing the product to high mechanical forces, for example through frequent transport or rough handling, or storing the product for a long time may cause deviations and a decrease in the measurement accuracy. Periodically carry out test measurements and perform the field adjustments indicated in the User Manual before using the product.</p>

6.2 Storage

Product	<p>Respect the temperature limits when storing the equipment, particularly in summer if the equipment is inside a vehicle. Refer to 7 Technical Data for information about temperature limits.</p>
Li-Ion batteries	<ul style="list-style-type: none">• Refer to 7 Technical Data for information about storage temperature range• Remove batteries from the product and the charger before storing• After storage recharge batteries before using• Protect batteries from damp and wetness. Wet or damp batteries must be dried before storing or use• A storage temperature range of 0 °C to +30 °C / +32 °F to +86 °F in a dry environment is recommended to minimize self-discharging of the battery• At the recommended storage temperature range, batteries containing a 40% to 50% charge can be stored for up to one year. After this storage period the batteries must be recharged

6.3

Cleaning and Drying

Product and accessories

- Blow dust off lenses and prisms.
 - Never touch the glass with your fingers.
 - Use only a clean, soft, lint-free cloth for cleaning. If necessary, moisten the cloth with water or pure alcohol. Do not use other liquids; these may attack the polymer components.
-

Fogging of prisms

Prisms that are cooler than the ambient temperature tend to fog. It is not enough simply to wipe them. Keep them for some time inside your jacket or in the vehicle to allow them to adjust to the ambient temperature.

Damp products

Dry the product, the transport container, the foam inserts and the accessories at a temperature not greater than 40 °C /104 °F and clean them. Remove the battery cover and dry the battery compartment. Do not repack until everything is completely dry. Always close the transport container when using in the field.

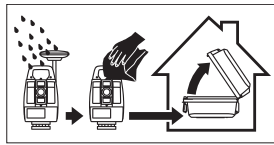

Cables and plugs

Keep plugs clean and dry. Blow away any dirt lodged in the plugs of the connecting cables.

6.4

Maintenance



An inspection of the product must be done in a Leica Geosystems authorised service workshop. Leica Geosystems recommends an inspection of the product every 12 months.

As MS60/TS60/TM60 instruments are equipped with a self-surveillance system designed for maximum motor performance and long maintenance cycles Leica Geosystems recommends inspection of the product whenever indicated in the message line of the user interface.

7 Technical Data

7.1 Angle Measurement

Accuracy	Type	Standard deviation Hz, V ISO 17123-3		Display least count	
		["]	[mgon]	["]	[mgon]
	TM60 R1000/ TM60 I R1000	0.5	0.15	0.1	0.01
	1	0.30	0.1	0.01	
TS60 R1000	0.5	0.15	0.1	0.01	
MS60 R2000	1	0.30	0.1	0.01	

Characteristics Absolute, continuous, diametric.

7.2 Distance Measurement with Reflectors

Range

For TS60/TM60 - R1000:

Reflector	Range A		Range B		Range C	
	[m]	[ft]	[m]	[ft]	[m]	[ft]
Standard prism (GPR1, GPH1P)	1800	6000	3000	10000	3500	12000
360° prism (GRZ4, GRZ122)	800	2600	1500	5000	2000	7000
360° Mini prism (GRZ101)	450	1500	800	2600	1000	3300
Mini prism (GMP101)	800	2600	1200	4000	2000	7000
Reflector tape (GZM31) 60 mm x 60 mm	150	500	250	800	250	800
Machine Automa- tion power prism (MPR122)	800	2600	1500	5000	2000	7000

 For Machine Control purposes only!

Shortest measuring distance: 0.9 m

For MS60 - R2000:

Reflector	Range A		Range B		Range C	
	[m]	[ft]	[m]	[ft]	[m]	[ft]
Standard prism (GPR1, GPH1P)	2200	7300	7500	24600	>10000	>32800
360° prism (GRZ4, GRZ122)	1200	4000	2250	7500	3000	10500
360° Mini prism (GRZ101)	670	2250	1200	3900	1500	5000

Reflector	Range A		Range B		Range C	
	[m]	[ft]	[m]	[ft]	[m]	[ft]
Mini prism (GMP101)	1200	4000	1800	6000	3000	10500
Reflector tape (GZM31) 60 mm x 60 mm	220	750	375	1200	370	1200
Machine Automation power prism (MPR122)	1200	4000	2250	7500	3000	10500

 For Machine Control purposes only!

Shortest measuring distance: 1.5 m

Atmospheric conditions

Range	Description
A	Strong haze, visibility 5 km; or strong sunlight, severe heat shimmer
B	Light haze, visibility about 20 km; or moderate sunlight, slight heat shimmer
C	Overcast, no haze, visibility about 40 km; no heat shimmer



Measurements can be made to reflector tapes over the entire range without external ancillary optics.

Accuracy

Accuracy refers to measurements to standard prisms.

For TS60/TM60 - R1000:

Distance measuring mode	Standard deviation ISO 17123-4, standard prism	Standard deviation ISO 17123-4, tape**	Measurement time, typical [s]
Precise	0.6 mm + 1x10 ⁻⁶ D*	1 mm + 1x10 ⁻⁶ D	7
Standard	1 mm + 1x10 ⁻⁶ D	1 mm + 1x10 ⁻⁶ D	2.4
Fast	2 mm + 1x10 ⁻⁶ D	3 mm + 1x10 ⁻⁶ D	2.0
Continuously	3 mm + 1x10 ⁻⁶ D	3 mm + 1x10 ⁻⁶ D	< 0.15
Averaging	1 mm + 1x10 ⁻⁶ D	1 mm + 1x10 ⁻⁶ D	-

D is the measured distance in millimeters.

Beam interruptions, severe heat shimmer and moving objects within the beam path can result in deviations of the specified accuracy.

* Atmospheric conditions type C, range up to 1000 m, GPH1P reflector

** Target aligned to instrument

For MS60 - R2000:

Distance measuring mode	Standard deviation ISO 17123-4, standard prism	Standard deviation ISO 17123-4, tape*	Measurement time, typical [s]
Standard	1 mm + 1.5x10 ⁻⁶ D	1 mm + 1.5x10 ⁻⁶ D	1.5
Fast	2 mm + 1.5x10 ⁻⁶ D	3 mm + 1.5x10 ⁻⁶ D	1.0
Continuously	2 mm + 1.5x10 ⁻⁶ D	3 mm + 1.5x10 ⁻⁶ D	>0.05**
Averaging	1 mm + 1.5x10 ⁻⁶ D	1 mm + 1.5x10 ⁻⁶ D	-

D is the measured distance in millimeters.

Beam interruptions, severe heat shimmer and moving objects within the beam path can result in deviations of the specified accuracy.

* Target aligned to instrument

** Auto point application increases the measurement time

Characteristics

Type	Description
Type	Coaxial, visible red laser
Carrier wave	658 nm
Measuring system	R1000: System Analyzer Basis 100 MHz - 150 MHz R2000: Wave Form Digitizer

7.3

Distance Measurement without Reflectors

Range

R1000

Kodak Gray Card	Range D		Range E		Range F	
	[m]	[ft]	[m]	[ft]	[m]	[ft]
White side, 90 % reflective	800	2630	1000	3280	>1000	>3280
Grey side, 18 % reflective	400	1320	500	1640	>500	>1640

R2000

Kodak Gray Card	Range D		Range E		Range F	
	[m]	[ft]	[m]	[ft]	[m]	[ft]
White side, 90 % reflective	1500	4920	2000	6560	>2000	>6560
Grey side, 18 % reflective	750	2460	1000	3280	>1000	>3280

Range of measurement:

TS60/TM60 R1000: 0.9 m - 1200 m

MS60 R2000: 1.5 m - 2400 m

Distance measurements below 1.5 m are not possible.

Atmospheric conditions

Range	Description
D	Object in strong sunlight, severe heat shimmer

Range	Description
E	Object in shade, or overcast
F	Underground, night and twilight

Accuracy

For TS60/TM60 - R1000:

Standard measuring	Standard deviation ISO 17123-4	Measure time, typical [s]	Measure time, maximum [s]
0 m - 500 m	2 mm + $2 \times 10^{-6}D$	2*	15
>500 m	4 mm + $2 \times 10^{-6}D$	6	15

D is the measured distance in millimeters.

Object in shade, sky overcast. Beam interruptions, severe heat shimmer and moving objects within the beam path can result in deviations of the specified accuracy. The display resolution is 0.1 mm.

* Up to 50 m

For MS60 - R2000:

Standard measuring	Standard deviation ISO 17123-4	Measure time, typical [s]	Measure time, maximum [s]
0 m - 500 m	2 mm + $2 \times 10^{-6}D$	1.5	14
>500 m	4 mm + $2 \times 10^{-6}D$	4	14

D is the measured distance in millimeters.

Object in shade, sky overcast. Beam interruptions, severe heat shimmer and moving objects within the beam path can result in deviations of the specified accuracy. The display resolution is 0.1 mm.

Characteristics

Type	Description
Type	Coaxial, visible red laser
Carrier wave	658 nm
Measuring system	R1000: System Analyzer Basis 100 MHz - 150 MHz R2000: Wave Form Digitizer

Laser dot size

Distance [m]	Laser dot size, approximately [mm]
at 30	7 × 10
at 50	8 × 20
at 100	16 × 25

7.4

Distance Measurement - Long Range (LO mode)



This chapter is valid for TS60/TM60.

Range

Reflector	Range A		Range B		Range C	
	[m]	[ft]	[m]	[ft]	[m]	[ft]
Standard prism (GPR1, GPH1P)	2200	7300	7500	24600	>10000	>32800
Range of measurement:	1000 m to 12000 m					
Display unambiguous:	up to 12000 m					

Atmospheric conditions

Range	Description
A	Strong haze, visibility 5 km; or strong sunlight, severe heat shimmer
B	Light haze, visibility about 20 km; or moderate sunlight, slight heat shimmer
C	Overcast, no haze, visibility about 40 km; no heat shimmer

Accuracy

Standard measuring	Standard deviation ISO 17123-4	Measure time, typical [s]	Measure time, maximum [s]
Long Range	3 mm + 1x10 ⁻⁶ D	2.5	12

D is the measured distance in millimeters.

Beam interruptions, severe heat shimmer and moving objects within the beam path can result in deviations of the specified accuracy. The display resolution is 0.1 mm.

Characteristics

Type	Description
Principle	Phase measurement
Type	Coaxial, visible red laser
Carrier wave	658 nm
Measuring system	System Analyzer Basis 100 MHz - 150 MHz

7.5**Automatic Target Aiming (ATRplus)****Range of target aiming/
target locking****For MS60/TS60:**

Prism	Range (Target Aiming)		Range (Target Locking)	
	[m]	[ft]	[m]	[ft]
Standard prism (GPR1)	1500	5000	1000	3300
360° prism (GRZ4, GRZ122)	1000	3300	1000	3300
360° Mini prism (GRZ101)	450	1500	250	830
Mini prism (GMP101)	900	3000	600	2000

Prism	Range (Target Aiming)		Range (Target Locking)	
	[m]	[ft]	[m]	[ft]
Reflector tape (GZM31) 60 mm x 60 mm	55	190	not qualified	

Machine Automation power prism (MPR122)	750	2500	650	2200
---	-----	------	-----	------

 For Machine Control purposes only!

 The maximum range depends on the atmospheric condition. Rain, strong sunlight or severe heat shimmer can decrease the maximum range.

Shortest measuring distance: 360° prism (Target aiming): 1.5 m

Shortest measuring distance: 360° prism (Target locking): 5 m

For TM60:

Prism	Range ATR mode up to*	
	[m]	[ft]

Standard prism (GPR1)	3000	9900
-----------------------	------	------

360° prism (GRZ4, GRZ122)	1500	5000
---------------------------	------	------

360° Mini prism (GRZ101)	700	2310
--------------------------	-----	------

Mini prism (GMP101)	1000	3300
---------------------	------	------

Reflector tape (GZM31) 60 mm x 60 mm	45	150
--------------------------------------	----	-----

Machine Automation power prism (MPR122)	1200	3960
---	------	------

 For Machine Control purposes only!

 The maximum range can be restricted by poorer conditions, for example rain.

* Atmospheric conditions type C, target aligned to instrument

Shortest measuring distance: 360° prism ATR: 1.5 m

ATRplus accuracy with the GPR1 prism

ATRplus angle accuracy Hz, V (std. dev. ISO 17123-3, atmospheric conditions type C):

Type	Accuracy
TS60/TM60, 0.5"	0.5 " (0.15 mgon)
MS60/TM60, 1"	1 " (0.3 mgon)

Maximum speed in lock mode

Type		Direction of prism movement	
		Tangential	Radial
TS60	Prism Lock only	44 m/s at 20 m	25 m/s
	Prism Lock with Measure distance: Continuously	6 m/s at 20 m	6 m/s
MS60	Prism Lock only	44 m/s at 20 m	25 m/s
	Prism Lock with Measure distance: Continuously	8 m/s at 20 m	11 m/s



A tangential movement means the prism is passing by the instrument at the specified distance.

A radial movement means the prism is moving away from or towards the instrument in the line of sight direction.

Searching

Type	Value
Typical search time in field of view	1.5 s
Field of view	TS60/MS60: 1°25'/1.55 gon TM60: 0°28'/0.52 gon
Definable search window	Yes

Characteristics

Type	Description
Principle	Digital image processing
Type	Infrared laser

7.6

Scanning

Availability

Available for MS60 R2000 and on CS when connected to MS60 R2000.

Scan speed

Measurement Rate	Maximum Scan Speed
8000 Hz	Up to 8000 points per second
Scan Path	Maximum Rotation Speed
Horizontal	400 gon per second
Vertical	200 gon per second

Range

The following ranges refer to optimal measurement conditions (object in shade, sky overcast, static target object).

Mode	Kodak Grey Card (Albedo 90%)	Range, up to	
		[m]	[ft]
30 kHz	White side, 90% Albedo	60	200
8 kHz		150	490
4 kHz		200	660
1000 Hz		300	980
250 Hz		400	1310

Mode	Kodak Grey Card (Albedo 90%)	Range, up to	
		[m]	[ft]
62 Hz		500	1640
>1 Hz		1000	3280
Shortest measuring distance:		1.5 m	

Accuracy

Range noise* (1 sigma; Kodak Grey Card (Albedo 90%)):

Distance	30 kHz	8 kHz	1000 Hz	1 Hz
10 m	2.0 mm	1.0 mm	0.6 mm	0.4 mm
25 m	2.2 mm	1.2 mm	0.8 mm	0.5 mm
50 m	3.0 mm	1.5 mm	1.0 mm	0.6 mm
100 m	-	5.0 mm	2.0 mm	0.8 mm
200 m	-	-	6.0 mm	1.8 mm

Object in shade, sky overcast. Beam interruptions, severe heat shimmer and moving objects within the beam path can result in deviations of the specified range noise and accuracy.

- * Range noise describes the standard deviation of the scan points residuals to the modelled surface:
- Plane surface target
 - Perpendicular orientation of the plane target to the measurement direction
 - Modelled plane best fitted into the point cloud

The absolute position accuracy of a modelled surface is similar to an RL single measurement:

Standard measuring	Standard deviation ISO 17123-4
0 m - 500 m	2 mm + $2 \times 10^{-6}D$
>500 m	4 mm + $2 \times 10^{-6}D$

D is the measured distance in millimeters.

Scan duration

Type	Scan area	Resolution	Duration
Full dome scan	400 gon x 155 gon	50 mm @ 15 m	12 min
Band scan	400 gon x 50 gon	12.5 mm @ 50 m	45 min

7.7

PowerSearch (PS)

Range

Reflector	Range	
	[m]	[ft]
Standard prism (GPR1)	300	1000
360° prism (GRZ4, GRZ122)	300*	1000*
360° mini prism (GRZ101)	Not recommended	

Reflector	Range	
	[m]	[ft]
Mini prism (GMP101)	100	330

Measurements at the vertical limits of the fan or under unfavourable atmospheric conditions may reduce the maximum range. (*optimally aligned to the instrument)

Shortest measuring distance: 1.5 m

Searching

Type	Value
Typical search time	5 - 10 s
Rotating speed	up to 100 gon/s
Default search area	Hz: 400 gon, V: 40 gon
Definable search windows	Yes

Characteristics

Type	Description
Principle	Digital signal processing
Type	Infrared laser

7.8

LOC8 Theft Deterrence and Location Device (optional)

Internal battery

Battery	Capacity
Li-Ion	800 mAh Recharged by the total station battery when instrument is switched on Up to 5 days Depending on mode of operation and cellular network conditions

Tracking period

Update rate up to 1 minute

Interfaces

Wi-Fi: 802.11 b/g/n

Environmental specifications

Temperature	
Operating temperature [°C]	Storage temperature [°C]
-20 to +60	-20 to +60

7.9

Overview Camera

Overview camera

Type	Value
Sensor	5 Mpixel CMOS sensor
Focal length	21mm
Field of view	15.5° x 11.7° (19.4° diagonal)
Frame rate	≤20 frames per second

Type	Value
Focus	2 m (6.6 ft) to infinity at zoom level 1 x 7.5 m (24.6 ft) to infinity at zoom level 4 x
Image storage	JPEG up to 5 Mpixel (2560 x 1920)
Zoom	4-step (1x, 2x, 4x, 8x)
Whitebalance	Automatic and user configurable
Brightness	Automatic and user configurable

7.10

Telescope Camera

Telescope camera

Type	Value
Sensor	5 Mpixel CMOS sensor
Focal length	At ∞ 231 mm
Field of view	1.5° diagonal
Frame rate	≤20 frames per second
Focus	Servofocus: Manual motorised focus, available for all variants instrument types Autofocus: Automatic focusing, available for instruments with imaging functionality
Time to focus	Typical 2 s
Focus range	1.7 m to infinity
Image storage	JPEG up to 5 Mpixel (2560 x 1920)
Zoom, digital	4-step (1x, 2x, 4x, 8x)
Whitebalance	Automatic and user configurable
Brightness	Automatic and user configurable

7.11

SmartStation

7.11.1

SmartStation Accuracy



Measurement precision and accuracy in position and accuracy in height are dependent upon various factors including the number of satellites tracked, constellation geometry, observation time, ephemeris accuracy, ionospheric disturbance, multipath and resolved ambiguities. Figures quoted assume normal to favourable conditions.

Times required are dependent upon various factors including number of satellites, geometry, ionospheric conditions, multipath and so on. GS and GLONASS can increase performance and accuracy by up to 30 % relative to GS only. A full Galileo and GS L5 constellation will further increase measurement performance and accuracy.

Accuracy

Type	Position accuracy
Horizontal	10 mm + 1 ppm
Vertical	20 mm + 1 ppm

When used within reference station networks the position accuracy is in accordance with the accuracy specifications provided by the reference station network.

Initialisation

Type	Description
Method	Real-time (RTK)
Reliability of initialisation	Better than 99.99 %
Time of initialisation	Typically 8 s, with 5 or more satellites on L1 and L2
Range	Up to 50 km, assuming reliable data-link is available

RTK data formats

Formats for data reception:

Leica, Leica 4G, CMR, CMR+, RTCM 2.2, 2.3, 3.0, 3.1, 3.2 MSM

7.11.2

SmartStation Dimensions

SmartStation dimensions

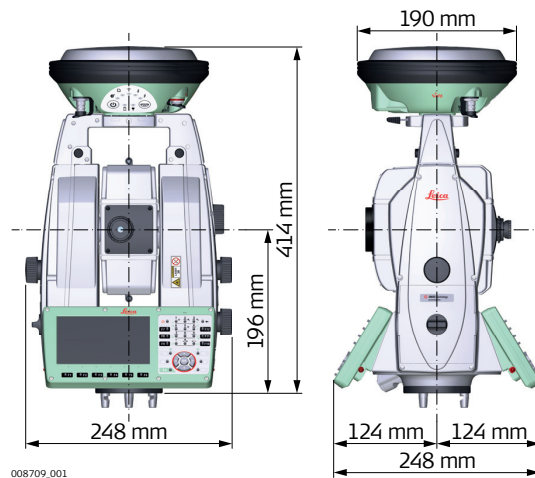

7.12

General Technical Data of the Product

System accuracy

Several factors can influence the accuracy of the system for determining the location of a prism:

- Internal ATRplus accuracy
- Angular accuracy of the instrument
- Type and centring accuracy of the prism
- Selected EDM measuring program
- External measuring conditions

Therefore, the overall pointing accuracy of the determined point location can be lower than the given angular accuracy and the ATRplus accuracy.

The following paragraphs provide a short overview of these influencing factors and their possible intensities.

Angular accuracy

The accuracy of angular measurements depends on the instrument type. The angular accuracy for total stations is typically in the range from 0.5" to 5". The resulting error depends on the measurement distance.

The table shows possible deviations for typical angular accuracies. 1" and 3" are examples.

Angular accuracy	Possible deviation* at 100 m distance
1"	~0.5 mm
3"	~1.5 mm

* Orthogonal to the line of sight.



Refer to the data sheet of the respective instrument model for information about the angular accuracy.

EDM accuracy

The distance measurement accuracy consists of two parts: a fixed value and a distance-dependent value.

Example: "Single measurements: 1 mm + 1.5x10⁻⁶D"

The EDM accuracies for prism and reflectorless measurements can differ. Additionally, the accuracies can differ depending on the used technologies.



Refer to the appropriate data sheet for information about the EDM accuracy.

ATRplus accuracy

Automatic target aiming accuracies, like those of the ATRplus, are in general the same as the stated angular accuracy. Therefore these accuracies are also distance-dependent parameters.

External impacts, like heat shimmer, rain (prism surface covered by rain drops), fog, dust, strong background lights, dirty targets, alignment of the targets etc. can have a significant influence on the automated target. In addition, the selected EDM mode affects the ATRplus performance. Under good environmental conditions and with a clean, properly aligned target the accuracy of the automated target aiming is equivalent to the manual target aiming (presumed valid calibration values).

Type and centring accuracy of the prism

The prism centring accuracy depends mainly on the used prism type, for example:

Prism type		Centring accuracy
Leica GPR1	Circular prism	1.0 mm
Leica GPH1P	Precision circular prism	0.3 mm
Leica GRZ122	360° prism	2.0 mm
Leica GRZ4	360° prism	5.0 mm



Refer to the white paper "Leica Surveying Reflectors" for information about the different centring accuracies.

More influencing factors

When determining absolute coordinates, the following parameters can also affect the resulting accuracy:

- Environmental conditions: temperature, air pressure and humidity
- Typical instrument errors, such as horizontal collimation error or index error.
- Proper functioning of laser plummet or optical plummet
- Correct horizontal levelling
- Setup of the target
- Quality of extra equipment, such as tribrach or tripod.

Telescope

Type	Value
Magnification	30x
Clear objective diameter	40mm
Focusing	1.7m/5.6ft to infinity
Field of view	1°30'/1.66gon. 2.7m at 100m

Compensator

Type	Setting accuracy		Setting range	
	["]	[mgon]	[']	[gon]
All types	0.5	0.15	4	0.07

Level

Type	Value
Compensation	Centralised quadruple axis compensation
Circular level sensitivity	6'/2mm
Electronic level resolution	2"

Control unit

Type	Description
Display	5" WVGA (800 x 480 pixels), colour, graphics capable LCD, illumination, touch screen
Keyboard	37 keys including 12 function keys and 12 alphanumeric keys, illumination
Angle display	360°", 360° decimal, 400 gon, 6400 mil, V %
Distance display	m, ft int, ft us, ft int inch, ft us inch
Position	TS60/MS60 both faces TM60 face I standard, face II optional
Touch screen	Screen protection foil on glass

Instrument ports

Name	Description
Serial/USB	<ul style="list-style-type: none"> • 8 pin LEMO-1 for power, communication, data transfer. • This port is located at the base of the instrument.

Name	Description
RadioHandle	<ul style="list-style-type: none"> Hotshoe connection for RadioHandle with Remote Mode and SmartAntenna Adapter with SmartStation. This port is located on top of the Communication side cover.
Bluetooth	<ul style="list-style-type: none"> Bluetooth module for communication. This port is housed within the Communication side cover.
WLAN	<ul style="list-style-type: none"> WLAN module for communication. This port is housed within the Communication side cover.
USB host port	<ul style="list-style-type: none"> USB memory stick port for data transfer.

Pin assignments of the 8 pin LEMO-1 port



- a Pin 1: USB data line (In or out)
- b Pin 2: USB data line (In or out)
- c Pin 3: Signal ground
- d Pin 4: RxD (RS232, receive data, In)
- e Pin 5: TxD (RS232, transmit data, Out)
- f Pin 6: Identification pin (In or out)
- g Pin 7: Power input, nominal +12 V (11 V - 16 V, In)
- h Pin 8: Not connected

Instrument dimensions

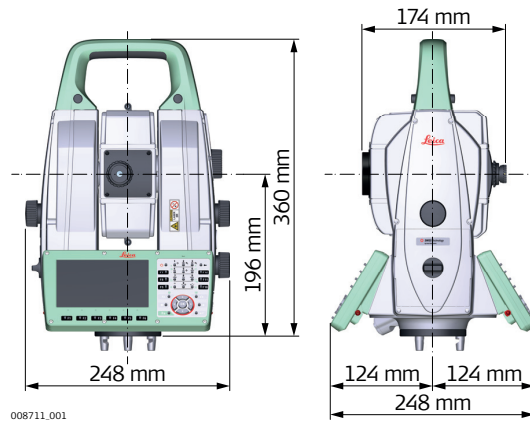

With RH18

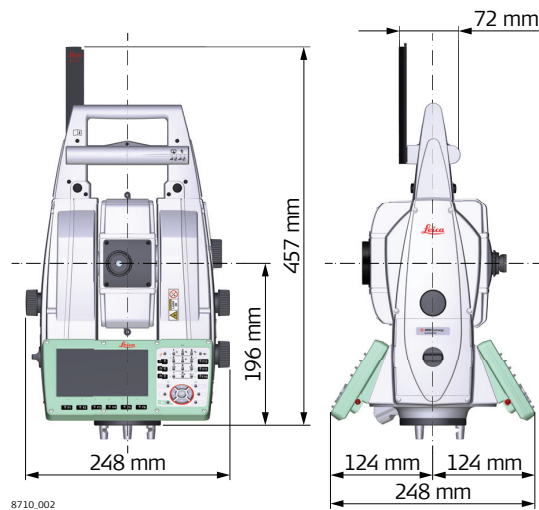

Weight

Type	MS60/TS60	TM60
Instrument without battery	7.27 kg	6.8 kg
Tribrach	0.8 kg	0.8 kg
Internal battery	0.43 kg	0.43 kg

Recording



Data can be recorded onto an SD card or into internal memory.

Type	Capacity [MB]	Number of measurements per MB
SD card	<ul style="list-style-type: none"> 1024 8192 	1750
Internal memory	<ul style="list-style-type: none"> 2048 	1750

AutoHeight plummet

Type	Description
Type	Visible red laser class 2
Location	In standing axis of instrument
Centering accuracy	Deviation from plumb line: 1.5 mm at 1.5 m instrument height
Diameter of laser point	2.5 mm at 1.5 m instrument height
Height accuracy ^{1,2}	1.0 mm
Measurement range ³	0.7 m to 2.7 m
Measurement time, typically	< 3 s

- 1 Standard deviation (1 sigma) over measurement range
 - 2 Object in shade, sky overcast, Kodak Grey Card (18% reflective), balanced tribrach foot screws
 - 3 Instrument height from tilting axis
-  Avoid dirt on cover glass.

-  Avoid line-of-sight obstructions. The full spot needs to be on target.
-  For best performance use the new Leica tripods. For older tripods, an upgrade of the screw is recommended.

Laser plummet

Type	Value
Type	Visible red laser class 2
Location	In standing axis of instrument
Accuracy	Deviation from plumbline: 1.5mm at 1.5m instrument height
Diameter of laser point	2.5mm at 1.5m instrument height

Operation

Type	Description
Three endless drives	For one and two hand manual operation
User defined Smartkey	Fast precision triggerkey for manual high precision measurements

Motorisation

Type	Description
Maximum acceleration	400 gon/s ²
Maximum rotating speed	200 gon/s
Time for change face	Typically 2.9 s

Power

Type	Description
External supply voltage	Nominal voltage 12.8 V DC Range 12 V-18 V
Standby power consumption	Typically 0.3 W
Operating power consumption	Typically 12 W (max. 40 W)

Internal battery

Type	Battery	Voltage	Capacity
GEB242	Li-Ion	14.8 V	5.8 Ah

External battery

Type	Battery	Voltage	Capacity
GEB373	Li-Ion	14.4V ==	20.1 Ah

Environmental specifications

Temperature

Type	Operating temperature [°C]	Storage temperature [°C]
All instruments	-20 to +50	-40 to +70
Leica SD cards	-40 to +80	-40 to +80
Battery internal	-20 to +55	-40 to +70
All chargers	0 to +50	-40 to +70

Protection against water, dust and sand

Type	Protection
All instruments	IP65 (IEC60529) / MIL-STD-810G, Methods 506.5 I and 507.5
All chargers	Only operate in dry environments, for example in buildings and vehicles.

Pollution degree

Type	Pollution
All instruments	4 Electrical equipment for outdoor use
All chargers	2 Electrical equipment for office environment

Humidity

Type	Protection
All instruments	Max 95 % non condensing The effects of condensation are to be effectively counteracted by periodically drying out the instrument.
All chargers	Only operate in dry environments, for example in buildings and vehicles.

Altitude

Type	Protection
All instruments	Unrestricted
All chargers	≤ 2000 m above sea level

Reflectors

Type	Additive Constant [mm]	ATRplus	PS
Standard prism, GPR1	0.0	yes	yes
Mini prism, GMP101	+17.5	yes	yes
360° prism, GRZ4 / GRZ122	+23.1	yes	yes
360° Mini prism, GRZ101	+30.0	yes	not recommended
Reflector tape S, M, L	+34.4	yes	no
Reflectorless	+34.4	no	no
Machine Automation power prism, MPR122	+28.1	yes	yes



For Machine Control purposes only!

There are no special prisms required for ATRplus or for PS.

**Electronic Guide Light
EGL**

Type	Description
Working range	5 m to 150 m (15 ft to 500 ft)
Position accuracy	5 cm at 100 m (1.97" at 330 ft)

**Automatic
corrections**

The following automatic corrections are made:

- Line of sight error
- Tilting axis error
- Earth curvature
- Circle eccentricity
- Compensator index error
- Vertical index error
- Standing axis tilt
- Refraction
- ATRplus zero point error
- Telescope camera zero point error

7.13

Scale Correction

**Use of scale
correction**

By entering a scale correction, reductions proportional to distance can be taken into account.

- Atmospheric correction.
- Reduction to mean sea level.
- Projection distortion.

**Atmospheric correc-
tion $\Delta D1$**

The slope distance displayed is correct if the scale correction in ppm, mm/km, which has been entered corresponds to the atmospheric conditions prevailing at the time of the measurement.

The atmospheric correction includes:

- Adjustments for air pressure
- Air temperature
- Relative humidity

For highest precision distance measurements, the atmospheric correction should be determined with an accuracy of 1 ppm. The following parameters must be redetermined:

- Air temperature to 1 °C
- Air pressure to 3 mbar
- Relative humidity to 20%

Air humidity

The air humidity influences the distance measurement if the climate is extremely hot and damp.

For high precision measurements, the relative humidity must be measured and entered along with the air pressure and the temperature.

Air humidity correction

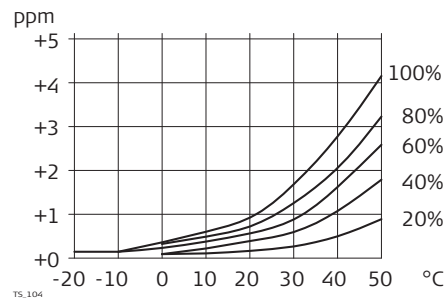

ppm Air humidity correction [mm/km]
 % Relative humidity [%]
 °C Air temperature [°C]

Index n

Type	Index n	Carrier wave [nm]
MS60 with R2000 (Wave Form Digitizer)	1.0002863	658
TS60/TM60 with R1000 Combined EDM (Phase Shift / System Analyzer)		

The index n is calculated from the formula of the IAG Resolutions (1999), and is valid for:

Air pressure p: 1013.25 mbar
 Air temperature t: 12 °C
 Relative air humidity h: 60 %

Formulas

Formula for visible red laser

$$\Delta D_1 = 286.338 - \left[\frac{0.29535 \cdot p}{(1 + \alpha \cdot t)} - \frac{4.126 \cdot 10^{-4} \cdot h}{(1 + \alpha \cdot t)} \right] \cdot 10^x$$

002419.002

ΔD_1 Atmospheric correction [ppm]

p Air pressure [mbar]

t Air temperature [°C]

h Relative humidity [%]

$\alpha = \frac{1}{273.15}$

$x = (7.5 \cdot t / (237.3 + t)) + 0.7857$

If the basic value of 60 % relative humidity as used by the EDM is retained, the maximum possible error in the calculated atmospheric correction is 2 ppm, 2 mm/km.

Reduction to mean sea level ΔD_2

The values for ΔD_2 are always negative and are derived from the following formula:

$$\Delta D_2 = - \frac{H}{R} \cdot 10^6$$

TS_106

ΔD_2 Reduction to mean sea level [ppm]

H Height of EDM above sea level [m]

R $6.378 \cdot 10^6$ m

Projection distortion ΔD_3

The magnitude of the projection distortion is in accordance with the projection system used in a particular country, for which official tables are generally

available. The following formula is valid for cylindrical projections such as that of Gauss-Krüger:

$$\Delta D_3 = \frac{X^2}{2R^2} \cdot 10^6$$

TS.107

- ΔD_3 Projection distortion [ppm]
- X Easting, distance from projection zero line with the scale factor 1 [km]
- R $6.378 \cdot 10^6$ m

In countries where the scale factor is not unity, this formula cannot be directly applied.

Atmospheric corrections °C

Atmospheric corrections in ppm with temperature [°C], air pressure [mb] and height [m] at 60% relative humidity.

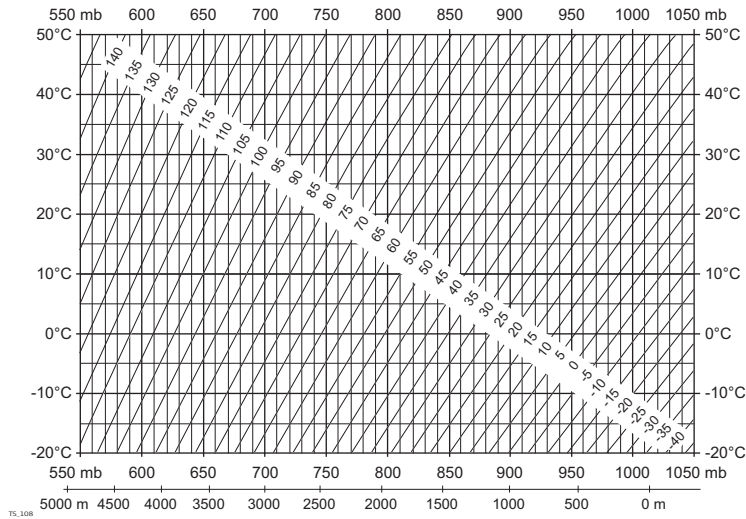

TS.108

Atmospheric corrections °F

Atmospheric corrections in ppm with temperature [°F], air pressure [inch Hg] and height [ft] at 60% relative humidity.

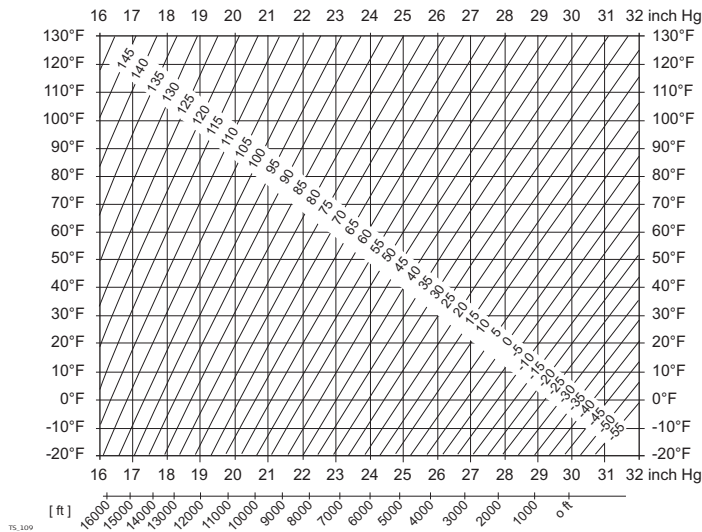

TS.109

Formulas

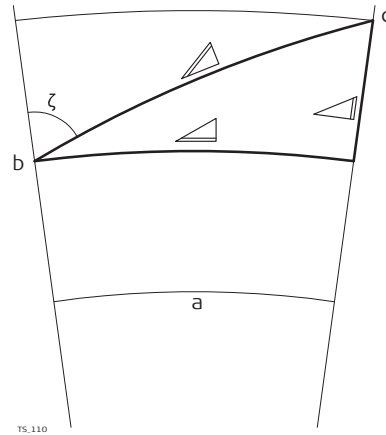

- a Mean Sea Level
- b Instrument
- c Reflector
- \triangle Slope distance
- \triangle Horizontal distance
- \triangle Height difference

The instrument calculates the slope distance, horizontal distance, height difference in accordance with the following formulas:

$$\triangle = D_0 \cdot (1 + \text{ppm} \cdot 10^{-6}) + AC$$

002425.002

- \triangle Displayed slope distance [m]
- D_0 Uncorrected distance [m]
- ppm Atmospheric scale correction [mm/km]
- AC Additive constant of the reflector [m]

$$\triangle = Y - A \cdot X \cdot Y$$

TS.112

$$\triangle = X + B \cdot Y^2$$

TS.113

- \triangle Horizontal distance [m]
- \triangle Height difference [m]
- Y $\triangle * |\sin \zeta|$
- X $\triangle * \cos \zeta$
- ζ Vertical circle reading
- A $(1 - k / 2) / R = 1.47 * 10^{-7} \text{ [m}^{-1}\text{]}$
- B $(1 - k) / (2 * R) = 6.83 * 10^{-8} \text{ [m}^{-1}\text{]}$
- k 0.13 (mean refraction coefficient)
- R $6.378 * 10^6 \text{ m}$ (radius of the earth)

Earth curvature ($1/R$) and mean refraction coefficient (k) are automatically taken into account when calculating the horizontal distance and height difference. The calculated horizontal distance relates to the station height and not to the reflector height.

Reflector types

The reduction formulas are valid for measurements to all reflector types:

- To prisms
- To reflector tape
- Reflectorless measurements

Formulas

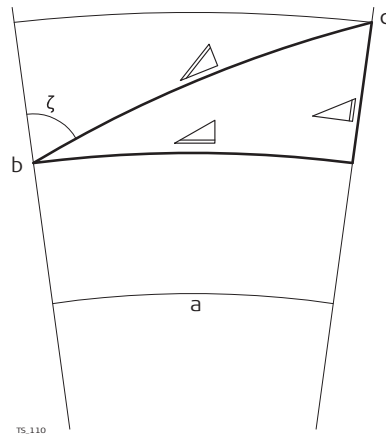

- a Mean Sea Level
- b Instrument
- c Reflector
- ▴ Slope distance
- ▴ Horizontal distance
- ▴ Height difference

The instrument calculates the slope distance, horizontal distance, height difference in accordance with the following formulas:

$$\triangle = D_0 \cdot (1 + \text{ppm} \cdot 10^{-6}) + AC$$

002425_002

- ▴ Displayed slope distance [m]
- D_0 Uncorrected distance [m]
- ppm Atmospheric scale correction [mm/km]
- AC Additive constant of the reflector [m]

$$\triangle = Y - A \cdot X \cdot Y$$

TS_112

$$\triangle = X + B \cdot Y^2$$

TS_113

- ▴ Horizontal distance [m]
- ▴ Height difference [m]
- Y ▴ * |sin ζ|
- X ▴ * cos ζ
- ζ Vertical circle reading
- A $(1 - k / 2) / R = 1.47 \cdot 10^{-7} \text{ [m}^{-1}\text{]}$
- B $(1 - k) / (2 \cdot R) = 6.83 \cdot 10^{-8} \text{ [m}^{-1}\text{]}$
- k 0.13 (mean refraction coefficient)
- R $6.378 \cdot 10^6 \text{ m}$ (radius of the earth)

Earth curvature (1/R) and mean refraction coefficient (k) are automatically taken into account when calculating the horizontal distance and height difference. The calculated horizontal distance relates to the station height and not to the reflector height.

Distance measuring program Averaging

In the distance measuring program Averaging, the following values are displayed:

- D Slope distance as arithmetic mean of all measurements
- s Standard deviation of a single measurement
- n Number of measurements

These values are calculated as follows:

$$\bar{D} = \frac{1}{n} \cdot \sum_{i=1}^n D_i$$

TS_114

\bar{D} Slope distance as arithmetic mean of all measurements
 \sum Sum
 D_i Single slope distance measurement
 n Number of measurements

$$s = \sqrt{\frac{\sum_{i=1}^n (D_i - \bar{D})^2}{n - 1}} = \sqrt{\frac{\sum_{i=1}^n D_i^2 - \frac{1}{n} (\sum_{i=1}^n D_i)^2}{n - 1}}$$

TS_115

s Standard deviation of a single slope distance measurement
 \sum Sum
 \bar{D} Slope distance as arithmetic mean of all measurements
 D_i Single slope distance measurement
 n Number of distance measurements

The standard deviation $S_{\bar{D}}$ of the arithmetic mean of the distance can be calculated as follows:

$$S_{\bar{D}} = \frac{s}{\sqrt{n}}$$

TS_116

$S_{\bar{D}}$ Standard deviation of the arithmetic mean of the distance
 s Standard deviation of a single measurement
 n Number of measurements

7.15

Conformity to National Regulations

7.15.1

TS60/MS60/TM60

Labelling MS60/TS60/ TM60

A MS60 instrument is shown.

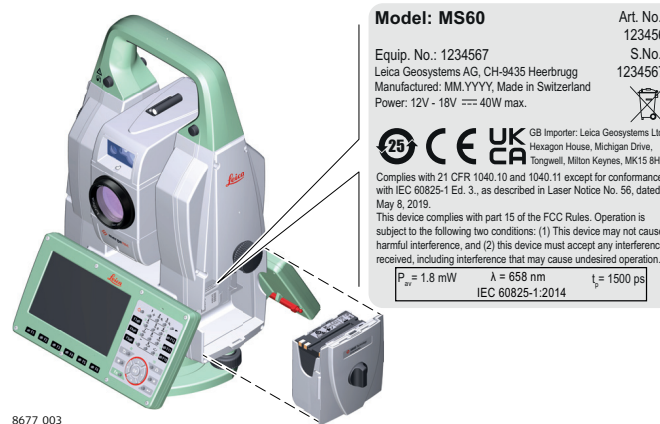

Labelling internal battery GEB242

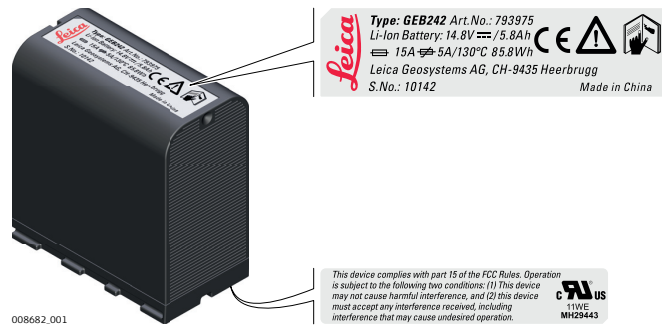

Labelling GKL311

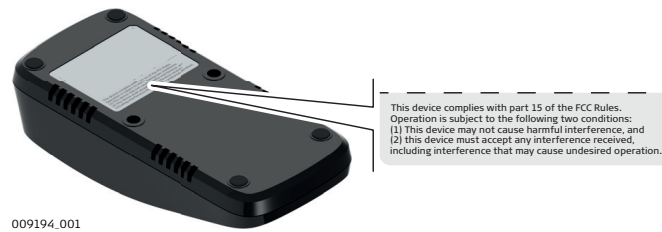

Labelling GKL341

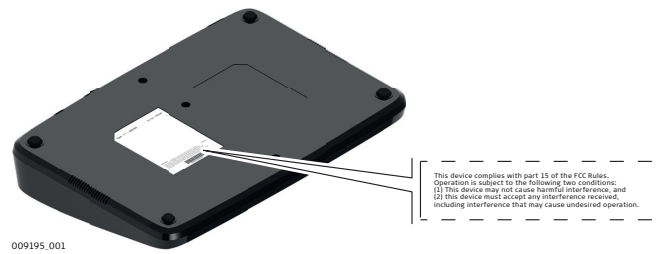

Frequency band

Type	Frequency Band [MHz]
Bluetooth	2402–2480
WLAN	2400–2473, channel 1–11

Output power

Type	Output Power [mW]
Bluetooth	<15
WLAN (802.11b)	100
WLAN (802.11g)	60

Antenna

Type	Antenna	Gain [dBi]	Connector	Frequency band [MHz]
Bluetooth	Integrated antenna	2	-	2400 - 2500
WLAN				

EU



Hereby, Leica Geosystems AG declares that the radio equipment type TS60/MS60/TM60 is in compliance with Directive 2014/53/EU and other applicable European Directives. The full text of the EU declaration of conformity is available at the following Internet address: <http://www.leica-geosystems.com/ce>.

This equipment has been tested and found to comply with the limits for a Class B digital device, pursuant to part 15 of the FCC Rules.

These limits are designed to provide reasonable protection against harmful interference in a residential installation.

This equipment generates, uses, and can radiate radio frequency energy and, if not installed and used in accordance with the instructions, it may cause harmful interference to radio communications.

However, there is no guarantee that interference does not occur in a particular installation.

If this equipment does cause harmful interference to radio or television reception, which can be determined by turning the equipment off and on, the user is encouraged to try to correct the interference by one or more of the following measures:

- Reorient or relocate the receiving antenna.
- Increase the separation between the equipment and the receiver.
- Connect the equipment into an outlet on a circuit different from that to which the receiver is connected.
- Consult the dealer or an experienced radio/TV technician for help.

Changes or modifications not expressly approved by Leica Geosystems for compliance could void the user's authority to operate the equipment.

Canada

CAN ICES-003 B/NMB-003 B

Japan

-
- This device is granted pursuant to the Japanese Radio Law (電波法).
 - This device should not be modified (otherwise the granted designation number will become invalid).

Others

The conformity for countries with other national regulations has to be approved prior to use and operation.

Labelling RadioHandle

RH17



8613_005

Model: RH17 Art. No.: 818467
 Leica Geosystems AG S.No.: 1234567
 CH-9435 Heerbrugg
 Manufactured: MM.YYYY
 Made in Austria
 Power: 7.4V /12.5V --- 0.2 A max.

Contains transmitter module:
 FCC ID: PVR0946
 IC: 5325A-0348

This device complies with part 15 of the FCC Rules. Operation is subject to the following two conditions: (1) This device may not cause harmful interference, and (2) this device must accept any interference received, including interference that may cause undesired operation.

UK CA GB Importer: Leica Geosystems Ltd.
 Hexagon House, Michigan Drive,
 Tongwell, Milton Keynes, MK15 8HT

Labelling RadioHandle

RH18

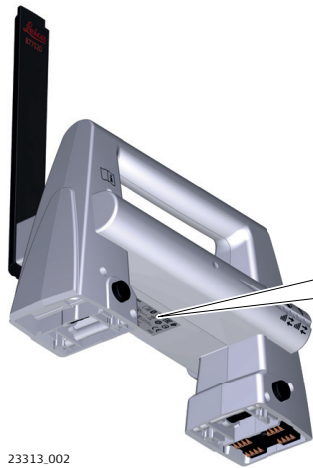

23313_002

Model: RH18 Art. No.: 922840
 Leica Geosystems AG S.No.: 1234567
 CH-9435 Heerbrugg
 Manufactured: MM.YYYY
 Made in Austria
 Power: 5.0V - 17.5V --- 3W max.

FCC ID: RFD-RH18
 IC: 3177A-RH18

This device complies with part 15 of the FCC Rules. Operation is subject to the following two conditions: (1) This device may not cause harmful interference, and (2) this device must accept any interference received, including interference that may cause undesired operation.

UK CA GB Importer: Leica Geosystems Ltd.
 Hexagon House, Michigan Drive,
 Tongwell, Milton Keynes, MK15 8HT

Frequency band

Type	Frequency Band [MHz]
RH17	Limited to 2402 - 2480
RH18	Limited to 2402 - 2480

Output power

Value
< 100 mW (e. i. r. p.)

Antenna

Type	$\lambda/2$ dipole antenna
Gain [dBi]	2
Connector	Special customized SMB

EU



Hereby, Leica Geosystems AG declares that the radio equipment type RadioHandle is in compliance with Directive 2014/53/EU and other applicable European Directives. The full text of the EU declaration of conformity is available at the following Internet address: <http://www.leica-geosystems.com/ce>.

This equipment has been tested and found to comply with the limits for a Class B digital device, pursuant to part 15 of the FCC Rules.

These limits are designed to provide reasonable protection against harmful interference in a residential installation.

This equipment generates, uses, and can radiate radio frequency energy and, if not installed and used in accordance with the instructions, it may cause harmful interference to radio communications.

However, there is no guarantee that interference does not occur in a particular installation.

If this equipment does cause harmful interference to radio or television reception, which can be determined by turning the equipment off and on, the user is encouraged to try to correct the interference by one or more of the following measures:

- Reorient or relocate the receiving antenna.
- Increase the separation between the equipment and the receiver.
- Connect the equipment into an outlet on a circuit different from that to which the receiver is connected.
- Consult the dealer or an experienced radio/TV technician for help.

USA

FCC ID: RFD-RH18, PVH0946
Part 15

Changes or modifications not expressly approved by Leica Geosystems for compliance could void the user's authority to operate the equipment.

Canada

CAN ICES-003 B/NMB-003 B
IC: 3177A-RH18, 5325A-0946

Others

The conformity for countries with other national regulations has to be approved prior to use and operation.

7.15.3

LOC8 Theft Deterrence and Location Device (optional)

Specific Absorption Rate (SAR)

The product meets the limits for the maximum permissible exposure of the guide-lines and standards which are force in this respect. The product must be used with the recommended antenna. A separation distance of at least 20 centimetres should be kept between the antenna and the body of the user or nearby person within the intended application.

Frequency bands, output power

Type	Frequency band	Output power ²⁾
GSM 900	880 - 960 MHz	GPRS: Maximal power: 29,13 dBm

²⁾ Conducted power for mobile technologies and EIRP for other technologies.

Type	Frequency band	Output power ³⁾
GSM 1800	1710 - 1880 MHz	GPRS: Maximal power: 29,13 dBm
WCDMA 900	880 - 960 MHz	Maximal power: 23,58 dBm
WCDMA 2100	1920 - 2170 MHz	Maximal power: 23,58 dBm
WLAN 2.4G Wi-Fi 802.11 b/g/n (20 MHz)	2412 - 2472 MHz	Receive only
WLAN 2.4G Wi-Fi 802.11 n (40 MHz)	2422 - 2462 MHz	Receive only
GPS	1.57542 GHz	Receive only

Output power

Type	Value
GSM	GPRS: Maximal power: 29,13 dBm
WCDMA	Maximal power: 23,58 dBm
GPS	Receive only
WLAN	Receive only

Antenna

Type	Antenna	Gain
GSM	Internal PIFA antenna	GSM 900: 0.23 dBi GSM 1800: 0.23 dBi
WCDMA	Internal antenna	WCDMA 900: 1.34 dB WCDMA 1200: 1.34 dBi
GPS	Internal antenna	0 dBi
WLAN	Internal PIFA antenna	-0.66 dBi

EU



Hereby, Leica Geosystems AG declares that the radio equipment type LOC8 is in compliance with Directive 2014/53/EU and other applicable European Directives.

The full text of the EU declaration of conformity is available at the following Internet address: <http://www.leica-geosystems.com/ce>.

USA

FCC ID: 2AAI6-TRKM015-LC
Part 15, 22 and 24

Others

The conformity for countries with other national regulations has to be approved prior to use and operation.

³⁾ Conducted power for mobile technologies and EIRP for other technologies.

Dangerous Goods Regulations

Many products of Leica Geosystems are powered by Lithium batteries.

Lithium batteries can be dangerous under certain conditions and can pose a safety hazard. In certain conditions, Lithium batteries can overheat and ignite.



When carrying or shipping your Leica product with Lithium batteries onboard a commercial aircraft, you must do so in accordance with the **IATA Dangerous Goods Regulations**.



Leica Geosystems has developed **Guidelines** on “How to carry Leica products” and “How to ship Leica products” with Lithium batteries. Before any transportation of a Leica product, we ask you to consult these guidelines on our web page ([IATA Lithium Batteries](#)) to ensure that you are in accordance with the IATA Dangerous Goods Regulations and that the Leica products can be transported correctly.



Damaged or defective batteries are prohibited from being carried or transported onboard any aircraft. Therefore, ensure that the condition of any battery is safe for transportation.

Software Licence Agreement

This product contains software that is preinstalled on the product, or that is supplied to you on a data carrier medium, or that can be downloaded by you online according to prior authorisation from Leica Geosystems. Such software is protected by copyright and other laws and its use is defined and regulated by the Leica Geosystems Software Licence Agreement, which covers aspects such as, but not limited to, Scope of the Licence, Warranty, Intellectual Property Rights, Limitation of Liability, Exclusion of other Assurances, Governing Law and Place of Jurisdiction. Please make sure, that at any time you fully comply with the terms and conditions of the Leica Geosystems Software Licence Agreement.

Such agreement is provided together with all products and can also be referred to and downloaded at the Leica Geosystems home page at [Hexagon – Legal Documents](#) or collected from your Leica Geosystems distributor.

You must not install or use the software unless you have read and accepted the terms and conditions of the Leica Geosystems Software Licence Agreement. Installation or use of the software or any part thereof, is deemed to be an acceptance of all the terms and conditions of such Licence Agreement. If you do not agree to all or some of the terms of such Licence Agreement, you must not download, install or use the software and you must return the unused software together with its accompanying documentation and the purchase receipt to the distributor from whom you purchased the product within ten (10) days of purchase to obtain a full refund of the purchase price.

Open Source information

The software on the product may contain copyright-protected software that is licenced under various open source licences.

Copies of the corresponding licences

- are provided together with the product (for example in the About panel of the software)
- can be downloaded on <http://opensource.leica-geosystems.com>

If foreseen in the corresponding open source licence, you may obtain the corresponding source code and other related data on <http://opensource.leica-geosystems.com>.

Contact

opensource@leica-geosystems.com in case you need additional information.

PART 2

AutoPole

9

Safety Directions

9.1

General Introduction

Description

The following directions enable the person responsible for the product, and the person who actually uses the equipment, to anticipate and avoid operational hazards.

The person responsible for the product must ensure that all users understand these directions and adhere to them.

About warning messages





Warning messages are an essential part of the safety concept of the instrument. They appear wherever hazards or hazardous situations can occur.

Warning messages...

- make the user alert about direct and indirect hazards concerning the use of the product.
- contain general rules of behaviour.

For the users' safety, all safety instructions and safety messages shall be strictly observed and followed! Therefore, the manual must always be available to all persons performing any tasks described here.

DANGER, WARNING, CAUTION and **NOTICE** are standardised signal words for identifying levels of hazards and risks related to personal injury and property damage. For your safety, it is important to read and fully understand the following table with the different signal words and their definitions! Supplementary safety information symbols may be placed within a warning message as well as supplementary text.

Type	Description
 DANGER	Indicates an imminently hazardous situation which, if not avoided, will result in death or serious injury.
 WARNING	Indicates a potentially hazardous situation or an unintended use which, if not avoided, could result in death or serious injury.
 CAUTION	Indicates a potentially hazardous situation or an unintended use which, if not avoided, may result in minor or moderate injury.
NOTICE	Indicates a potentially hazardous situation or an unintended use which, if not avoided, may result in appreciable material, financial and environmental damage.
	Important paragraphs which must be adhered to in practice as they enable the product to be used in a technically correct and efficient manner.

Additional symbols



Warning against explosive material.



Warning against flammable substances.



Product must not be opened or modified or tampered with.



Indicates the temperature limits at which the product may be stored, transported or used.

9.2

Definition of Use

Intended use

- Measuring pole length
- Measuring pole tilt and computing coordinates
- Verifying target ID
- Data transfer with Bluetooth®
- Data communication with external appliances
- Remote control of product
- Computing with software
- Laying out points and designs, for example from blueprint
- Automatic target search, recognition and tracking
- Measuring coordinates

Reasonably Foreseeable Misuse

- Use of the product without instruction
- Use outside of the intended use and limits
- Disabling of safety systems
- Removal of hazard notices
- Opening the product using tools, for example a screwdriver, unless this is permitted for certain functions
- Modification or conversion of the product
- Use after misappropriation
- Use of products with recognisable damage or defects
- Use with accessories from other manufacturers without the prior explicit approval of Leica Geosystems
- Deliberate dazzling of third parties
- Inadequate safeguards at the working site

9.3

Limits of Use

Environment

Suitable for use in an atmosphere appropriate for permanent human habitation. Not suitable for use in aggressive or explosive environments.

WARNING

Working in hazardous areas or close to electrical installations or similar situations

Life Risk.

Precautions:

- ▶ Local safety authorities and safety experts must be contacted by the person responsible for the product before working in such conditions.

9.4

Responsibilities

Manufacturer of the product

Leica Geosystems AG, CH-9435 Heerbrugg, hereinafter referred to as Leica Geosystems, is responsible for supplying the product, including the User Manual and original accessories, in a safe condition.

Person responsible for the product

The person responsible for the product has the following duties:

- To understand the safety instructions on the product and the instructions in the User Manual
- To ensure that the product is used in accordance with the instructions
- To be familiar with local regulations relating to safety and accident prevention
- To stop operating the system and inform Leica Geosystems immediately if the product and the application become unsafe
- To ensure that the national laws, regulations and conditions for the operation of the products are respected

9.5

Hazards of Use

NOTICE

Dropping, misusing, modifying, storing the product for long periods or transporting the product

Watch out for erroneous measurement results.

Precautions:

- ▶ Periodically carry out test measurements and perform the field adjustments indicated in the User Manual, particularly after the product has been subjected to abnormal use as well as before and after important measurements.

DANGER

Risk of electrocution

Because of the risk of electrocution, it is dangerous to use poles, levelling staffs and extensions in the vicinity of electrical installations such as power cables or electrical railways.

Precautions:

- ▶ Keep at a safe distance from electrical installations. If it is essential to work in this environment, first contact the safety authorities responsible for the electrical installations and follow their instructions.



WARNING

Lightning strike

If the product is used with accessories, for example masts, staffs, poles, you may increase the risk of being struck by lightning.

Precautions:

- ▶ Do not use the product in a thunderstorm.

WARNING

Distraction/loss of attention

During dynamic applications, for example stakeout procedures, there is a danger of accidents occurring if the user does not pay attention to the environmental conditions around, for example obstacles, excavations or traffic.

Precautions:

- ▶ The person responsible for the product must make all users fully aware of the existing dangers.

WARNING

Inadequate securing of the working site

This can lead to dangerous situations, for example in traffic, on building sites and at industrial installations.

Precautions:

- ▶ Always ensure that the working site is adequately secured.
- ▶ Adhere to the regulations governing safety, accident prevention and road traffic.

CAUTION

Not properly secured accessories

If the accessories used with the product are not properly secured and the product is subjected to mechanical shock, for example blows or falling, the product may be damaged or people can sustain injury.

Precautions:

- ▶ When setting up the product, make sure that the accessories are correctly adapted, fitted, secured, and locked in position.
- ▶ Avoid subjecting the product to mechanical stress.

For the AC/DC power supply:

WARNING

Electric shock due to use under wet and severe conditions

If unit becomes wet it may cause you to receive an electric shock.

Precautions:

- ▶ If the product becomes humid, it must not be used!
- ▶ Use the product only in dry environments, for example in buildings or vehicles.



- ▶ Protect the product against humidity.

For the AC/DC power supply:

WARNING

Unauthorised opening of the product

Either of the following actions may cause you to receive an electric shock:

- Touching live components
- Using the product after incorrect attempts were made to carry out repairs.

Precautions:

- ▶ Do not open the product!
 - ▶ Only Leica Geosystems authorised service centres are entitled to repair these products.
-

WARNING

Inappropriate mechanical influences to batteries

During the transport, shipping or disposal of batteries it is possible for inappropriate mechanical influences to constitute a fire hazard.

Precautions:

- ▶ Before shipping the product or disposing it, discharge the batteries by the product until they are flat.
 - ▶ When transporting or shipping batteries, the person in charge of the product must ensure that the applicable national and international rules and regulations are observed.
 - ▶ Before transportation or shipping, contact your local passenger or freight transport company.
-

WARNING

Exposure of batteries to high mechanical stress, high ambient temperatures or immersion into fluids

This can cause leakage, fire or explosion of the batteries.

Precautions:

- ▶ Protect the batteries from mechanical influences and high ambient temperatures. Do not drop or immerse batteries into fluids.
-

WARNING

Wet or moisture conditions

The housing around the battery has wiring which may produce a short-circuit.

Precautions:

- ▶ Do not place the battery system in water or expose it to moisture, lubricants, solvents or any other liquid.
-

WARNING

Improperly battery handling

Risk of fire, explosion or burn.

Precautions:

- ▶ Only replace battery with supported type.
- ▶ Prevent heating the battery above 70 °C.
- ▶ Never throw battery into fire.
- ▶ Do not disassemble, crush, or modify the battery.

WARNING

Short circuit of battery terminals

If battery terminals are short circuited e.g. by coming in contact with jewellery, keys, metallised paper or other metals, the battery can overheat and cause injury or fire, for example by storing or transporting in pockets.

Precautions:

- ▶ Make sure that the battery terminals do not come into contact with metallic/conductive objects.

WARNING

Improper disposal

If the product is improperly disposed of, the following can happen:

- If polymer parts are burnt, poisonous gases are produced which may impair health.
- If batteries are damaged or are heated strongly, they can explode and cause poisoning, burning, corrosion or environmental contamination.
- By disposing of the product irresponsibly you may enable unauthorised persons to use it in contravention of the regulations, exposing themselves and third parties to the risk of severe injury and rendering the environment liable to contamination.

Precautions:

▶



The product must not be disposed with household waste. Dispose of the product appropriately in accordance with the national regulations in force in your country. Always prevent access to the product by unauthorised personnel.

Product-specific treatment and waste management information can be received from your Leica Geosystems distributor.

WARNING

Improperly repaired equipment

Risk of injuries to users and equipment destruction due to lack of repair knowledge.

Precautions:

- ▶ Only authorised Leica Geosystems Service Centres are entitled to repair these products.

Description

The term Electromagnetic Compatibility is taken to mean the capability of the product to function smoothly in an environment where electromagnetic radiation and electrostatic discharges are present, and without causing electromagnetic disturbances to other equipment.

 CAUTION**Electromagnetic radiation**

Electromagnetic radiation can cause disturbances in other equipment.

Precautions:

- ▶ Although the product meets the strict regulations and standards which are in force in this respect, Leica Geosystems cannot completely exclude the possibility that other equipment may be disturbed.
-

 CAUTION**Use of the product with accessories from other manufacturers. For example, field computers, personal computers or other electronic equipment, non-standard cables or external batteries**

This may cause disturbances in other equipment.

Precautions:

- ▶ Use only the equipment and accessories recommended by Leica Geosystems.
 - ▶ When combined with the product, other accessories must meet the strict requirements stipulated by the guidelines and standards.
 - ▶ When using computers, two-way radios or other electronic equipment, pay attention to the information about electromagnetic compatibility provided by the manufacturer.
-

 CAUTION**Intense electromagnetic radiation. For example, near radio transmitters, transponders, two-way radios or diesel generators**

Although the product meets the strict regulations and standards which are in force in this respect, Leica Geosystems cannot completely exclude the possibility that the function of the product may be disturbed in such an electromagnetic environment.

Precautions:

- ▶ Check the plausibility of results obtained under these conditions.
-

CAUTION

Electromagnetic radiation due to improper connection of cables

If the product is operated with connecting cables, attached at only one of their two ends, the permitted level of electromagnetic radiation may be exceeded and the correct functioning of other products may be impaired. For example, external supply cables or interface cables.

Precautions:

- ▶ While the product is in use, connecting cables, for example product to external battery or product to computer, must be connected at both ends.
-

WARNING

Use of product with radio or digital cellular phone devices

Electromagnetic fields can cause disturbances in other equipment, installations, medical devices, for example pacemakers or hearing aids, and aircrafts. Electromagnetic fields can also affect humans and animals.

Precautions:

- ▶ Although the product meets the strict regulations and standards which are in force in this respect, Leica Geosystems cannot completely exclude the possibility that other equipment can be disturbed or that humans or animals can be affected.
 - ▶ Do not operate the product with radio or digital cellular phone devices in the vicinity of filling stations or chemical installations, or in other areas where an explosion hazard exists.
 - ▶ Do not operate the product with radio or digital cellular phone devices near medical equipment.
 - ▶ Do not operate the product with radio or digital cellular phone devices in aircrafts.
 - ▶ Do not operate the product with radio or digital cellular phone devices for long periods with the product immediately next to your body.
-

10

System Components

Support of AutoPole functionality

Term	Description
PoleHeight	Automatically measure height or length from the pole tip to the reflector and apply it to field software.
Tilt Compensation	Seamlessly measure and layout points with an arbitrary tilted reflector pole. Constantly show the quality of tilt compensated points in the field and store it with the point.
TargetID	Search and lock onto the target by verifying a specific ID on the fly.

	TS60/MS60	TM60
PoleHeight	✓	✓
Tilt Compensation*	✓	-
TargetID	✓	-

* Requires RH18 attached to TS instrument

11

Setting Up AutoPole

AutoPole setup

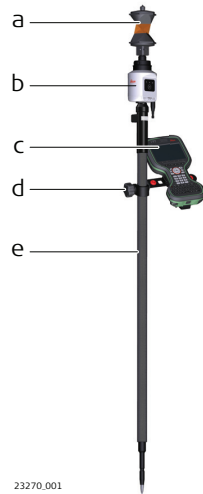

23270_001

- a Reflector
- b AP20 AutoPole
- c Field controller on GHT66 holder, optional
- d GHT63 clamp
- e AP Reflector Pole

Attaching AP20 onto AP Reflector Pole



AP20 is compatible with AP Reflector Poles CRP4, CRP5, GLS51 and GLS51F.

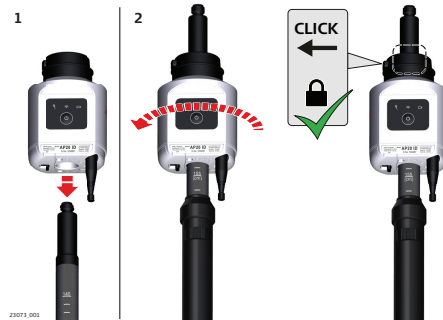

1. Place the AP20 over the top of the AP Reflector Pole and slide it down as far as it will go.
2. Rotate the AP20 until it snaps into one of the lock positions.
3. To remove the AP20, press in the lock button to release it, then slide it up and off the top of the AP reflector pole.

Attaching AP20 onto AP Mini Pole



AP20 is compatible with AP Mini Pole GLS53 and GLS54.

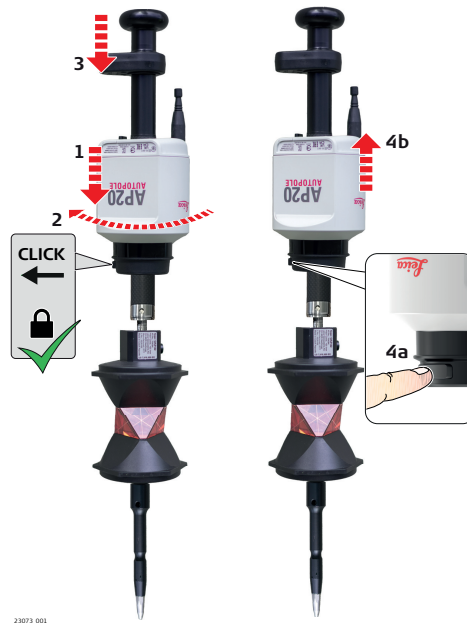

1. Place the AP20 over the top of the AP Mini Pole and slide it down as far as it will go.
2. Rotate the AP20 until it snaps into one of the lock positions.
3. Attach the handle with the bubble (CRP14).
4. To remove the AP20, press in the lock button to release it, then slide it up and off the top of the AP reflector pole.

Pole handling with AP Reflector Pole

	Standard use	Reversed use CRP10 attached on reflector
--	--------------	---

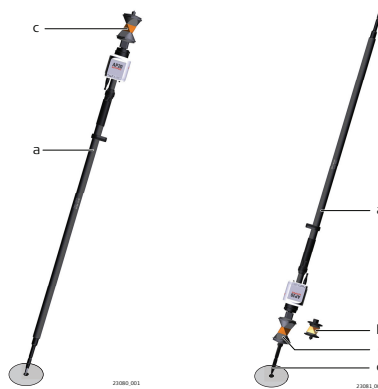

- a GLS51
- b MPR122
- c GRZ122
- d CRP10 with optional CRP13*

PoleHeight**	✓	–
Tilt Compensation**	✓	✓ Refer to the manual of the field software for information about the setting.
TargetID**	✓	✓

* Feet adapter for the CRP10 tip

** Features depending on AP20 variant

☞ For reversed use, the target height must be entered manually.

Reflector	Target height with exchangeable pole tip			
	CRP10		CRP10 + CRP13	
Unit	[m]	[ft]	[m]	[ft]
MPR122	0.200	0.656	0.305	1.000
GRZ122	0.228	0.748	0.333	1.093

Pole handling with AP Mini Pole

Standard use CRP10 attached on reflector

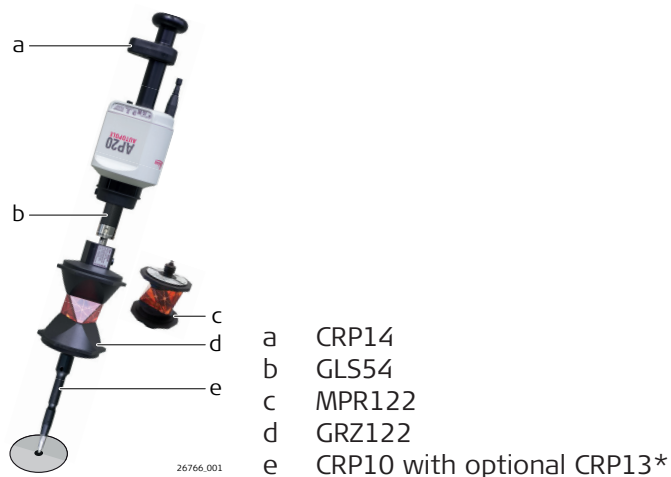

PoleHeight	–
Tilt Compensation**	✓ Refer to the manual of the field software for information about the setting.

TargetID** ✓

- * Feet adapter for the CRP10 tip
- ** Features depending on AP20 variant

☞ For reversed use, the target height must be entered manually.

Reflector	Target height with exchangeable pole tip			
	CRP10		CRP10 + CRP13	
Unit	[m]	[ft]	[m]	[ft]
MPR122	0.200	0.656	0.305	1.000
GRZ122	0.228	0.748	0.333	1.093

12

Battery for the AP20

Change battery step-by-step



GEB321 batteries must be used in the AP20. GEB211/GEB212 do NOT work with AP20.

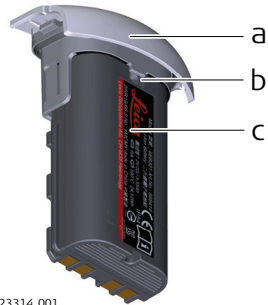

23314.001

- a Battery holder
- b Notch of battery holder
- c Battery GEB321



23315.001

1. Push the slide fastener of the battery holder in the direction of the arrow with the open-lock symbol.
2. Remove the battery holder from the compartment. Remove the battery from the holder.
3. To insert the battery, attach the battery to the batter holder. Align the battery to fit notch of battery holder.
4. Insert the battery holder into the compartment.
5. Push the slide fastener in the direction of the arrow with the close-lock symbol.

Software upload

In case a software upload for AP20 is indicated, the correct firmware file has to be selected. The firmware file depends on the AP20 model.

Model	Software type
AP20 H	AP20H_ID_Firmware.swu
AP20 ID	Covers all functions required.
AP20 T	AP20_T_Firmware.swu
AP20	Covers all functions required.

 Uploading software can take some time. Ensure that the battery is at least 20% full before you start the upload. Do not remove the battery during the upload process.

Software update instructions for all AP20 models:

1. Download the most recent firmware file from <https://myworld.leica-geosystems.com> to your local PC.
2. Connect AP20 to PC using GEV284 cable.
3. Copy the firmware file onto the AP20 memory device.
4. Disconnect GEV284 cable.
5. Switch AP20 off.
6. Switch AP20 on.
7. The upload starts automatically. During the upload, all three LEDs are flashing consecutively.
8. The update is complete when the Power LED on AP20 is constantly lit.

14

Working with the AutoPole

14.1

Overview

AutoPole functionality

Functionalities are listed according to the individual sales variants.

Functionality	AP20 H	AP20 ID	AP20 T	AP20
PoleHeight	✓	–	✓	✓
Tilt Compensation	–	–	✓	✓
TargetID	–	✓	–	✓

- ➔ AP20 can only be used in combination with an AP Reflector Pole (CRP4, CRP5, GLS51 and GLS51F) or an AP Mini Pole (GLS53 or GLS54).
- ➔ Establish a Bluetooth connection between the AP20 and the field controller or the total station in order to be operative. Use the connection wizard.

Supported connection types

AutoPole functionalities are supported in 2-person operation and 1-person operation. Use the field software on the total station or field controller to establish a Bluetooth connection.

In case of 1-person operation, first establish a connection between field controller and total station. Then use the field software on the field controller to establish a connection to the AutoPole.

- ➔ AP20 T and AP20 require a RH18 attached to total station.

14.2

PoleHeight

Description

The AP Reflector Pole can be extended to any of the given snap-lock positions in order to overcome obstacles.

As soon as a snap-lock position is reached, the attached AP20 receives the detected height from the AP Reflector Pole and transmits it to the field software of the connected total station or field controller.

The transmitted height corresponds to the current length between prism centre and pole tip, which is equivalent to the printed scale on the pole and the height input field within the field software.

- ➔ Valid height detection is limited to the snap-lock positions. Intermediate positions are indicated as invalid. Enter the height manually.
- ➔ Optional pole extensions are not taken into account.
- ➔ Transmitted heights can be overwritten manually.

Diagram

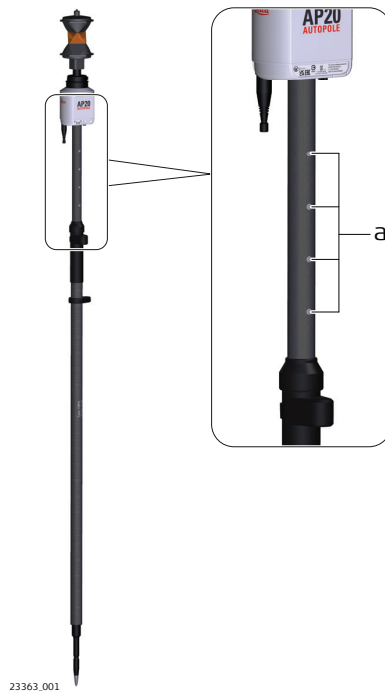

a Snap-lock positions

PoleHeight step-by-step

Action

- ☞ PoleHeight is only supported with sales variants AP20 H, AP20 T and AP20.
- ☞ PoleHeight can be used with:
 - Total station only (2-person operation)
 - Total station and field controller (1-person operation)
- 1. Enter a survey app, for example **Measure** or **Stake points**.
- 2. Physically extend or compress the pole to overcome obstacles.
- ☞ The height input field within Captivate will automatically update to current snap-lock height.
- ☞ 3D viewer is updated with the current height of the pole.
- 3. Measure or stake a point. The current height is applied to the coordinate calculation.

14.3

Tilt Compensation

Description

The AP Reflector Pole can be held in a slanting position over the point to be measured without checking the circular bubble on the pole.

When measuring a point, the pole tip must be stable on the point while the pole should be in slight movement. Tilt compensation is indicated by an icon and the Tilt LED and is maintained by natural pole movement, for example while moving to the next point to be measured.

Measurements are reliable and accurate even if the pole is not levelled as the tilt values are calculated by an Inertial Measurement Unit. Tilt values contain information about the 3D position of the pole.

Diagram



Tilt Compensation step-by-step

Action	Result
<p>☞ Tilt Compensation is only supported with sales variants AP20 T and AP20 connected via RH18 to an automated total station supporting Target Lock.</p>	
<p>☞ Tilt Compensation can be used with total station only (2-person operation) or with an additional field controller connected to a total station (1-person operation).</p>	
<p>1. Leica Captivate - Home: Settings\TS instrument\Measure & target</p>	
<p>2. AP tilt compensation</p>	<p>The screenshot shows the 'Measure & Target' settings menu. The 'AP tilt compensation' option is highlighted in green and set to 'On - to pole tip'. Other settings include 'Target' (Leica 360° prism), 'Aim at target' (With lock), and 'Measure distance' (Continuously).</p>
<p>3. OK</p>	
<p>4. Enter a survey app, for example Measure or Stake points.</p>	
<p>☞ Tilt Compensation is not supported within the Setup app.</p>	
<p>5. Press Start tilt.</p>	

Action	Result
--------	--------

☞ Move the pole for initialisation. Walking to the survey mark is sufficient. A message and a voice prompt indicate that the tilt compensation is being applied.

☞ The Tilt LED on the AP20 and the green background of the Target Lock icon within Captivate indicate when a tilt compensated measurement is possible. Refer to [15 LED Indicators](#).

6. 3D viewer is updated with the current pole alignment. The heading direction is the opposite side to the LED screen and ON/OFF button.

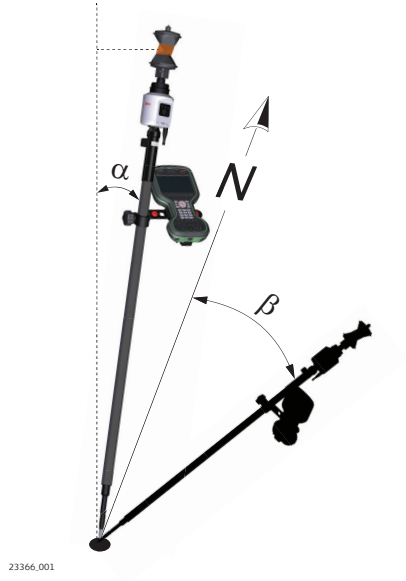

α Tilt toward vertical line
 β Direction of tilt toward North

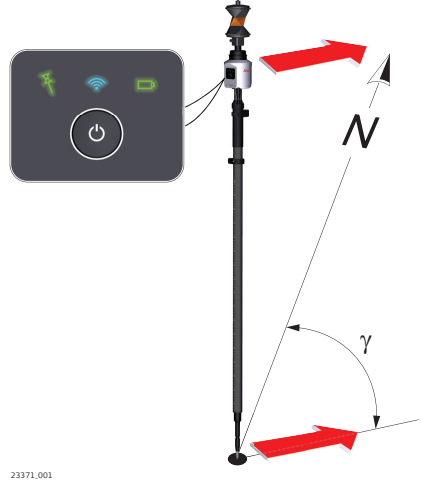

γ AP heading

Action	Result
--------	--------

7. **Measure points**
Leica Captivate - Home: Measure
 The position of the tilted AP20 is shown in the 3D viewer.
 Store points by pressing **Store**.

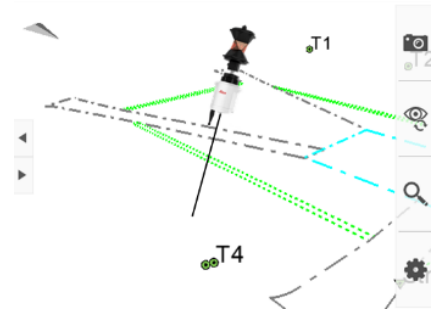

Application example:

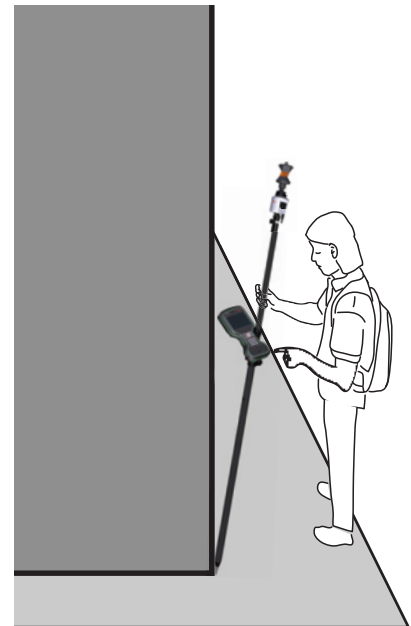

23383_001

8. **Stake points**
Leica Captivate - Home: Stake points
 The position of the tilted AP20 is shown in the 3D viewer.
 Stake out the point. The values are valid for the tip of the pole.

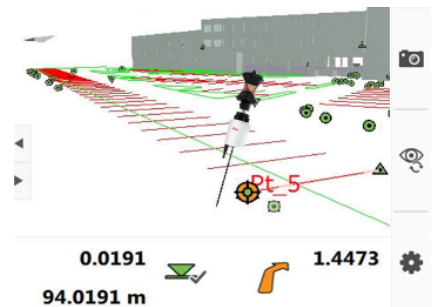

14.4

TargetID

Description

TargetID provides an automatic target search and identification on-the-fly. The common search methods, such as PowerSearch, are extended with an additional verification of an ID which is transmitted from the AP20. While the total station is performing a search, it ignores any other target or foreign reflections and only stops and locks onto the target above the AP20.

Diagram



a TargetID window, 360° coverage

TargetID step-by-step

Action	Result
<p>☞ TargetID is only supported with sales variants AP20 ID and AP20.</p> <p>☞ TargetID functionality requires a total station with PowerSearch capability.</p>	
<p>1. Leica Captivate - Home: Settings\TS instrument\Target search, TargetID page.</p>	
<p>2. Use TargetID: Check the check box.</p>	
<p>3. OK</p>	
<p>4. Start a target search. For example, use the icon Search & lock or PowerSearch.</p>	
<p>☞ The search includes identification on-the-fly and only stops at and locks onto the target above the AP20.</p>	

15

LED Indicators

Description of the AP20 ON/OFF button and status LEDs

Diagram

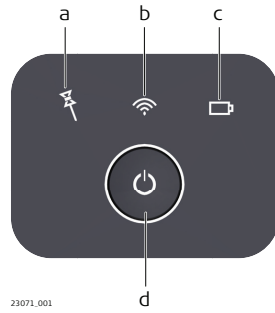

- a Tilt Compensation LED
- b Connectivity LED
- c Power LED
- d ON/OFF button

Description of the LED Indicators

LED	LED Status	Status of the Instrument
Tilt Compensation LED	off	Tilt compensation is unavailable or switched off.
	green	Tilt compensation is activated, compensation values are stored. Tilt compensation is being applied to the point measurement.
	red	Tilt compensation is activated, but currently not being applied to the point measurement.
Connectivity LED	off	AP20 is not powered or module is not ready.
	green	Bluetooth is visible for other instruments and ready for connecting.
	blue	Bluetooth has connected.
Power LED	off	Battery is not connected, flat or AP20 is switched off.
	green	Power is 21% - 100%.
	red	Power is 11% - 20%. The remaining time for which enough power is available depends on the type of survey, the temperature and the age of the battery.
	flashing red	Power is low (<10%).

16 Care and Transport

16.1 Transport

Transport in the field When transporting the equipment in the field, always make sure to carry the product in its original container.

Transport in a road vehicle Never carry the product loose in a road vehicle, as it can be affected by shock and vibration. Always carry the product in its container and secure it.
For products for which no container is available use the original packaging or its equivalent.

Shipping When transporting the product by rail, air or sea, always use the complete original Leica Geosystems packaging, container and cardboard box, or its equivalent, to protect against shock and vibration.

Shipping, transport of batteries When transporting or shipping batteries, the person responsible for the product must ensure that the applicable national and international rules and regulations are observed. Before transportation or shipping, contact your local passenger or freight transport company.

16.2 Storage

Product Respect the temperature limits when storing the equipment, particularly in summer if the equipment is inside a vehicle. Refer to [17 Technical Data](#) for information about temperature limits.

Li-Ion batteries

- Refer to [17 Technical Data](#) for information about storage temperature range
- Remove batteries from the product and the charger before storing
- After storage recharge batteries before using
- Protect batteries from damp and wetness. Wet or damp batteries must be dried before storing or use
- A storage temperature range of 0 °C to +30 °C / +32 °F to +86 °F in a dry environment is recommended to minimize self-discharging of the battery
- At the recommended storage temperature range, batteries containing a 40% to 50% charge can be stored for up to one year. After this storage period the batteries must be recharged

16.3 Cleaning and Drying

Product and accessories

- Use only a clean, soft, lint-free cloth for cleaning. If necessary, moisten the cloth with water or pure alcohol. Do not use other liquids; these may attack the polymer components.

Damp products Dry the product, the transport container, the foam inserts and the accessories at a temperature not greater than 40 °C /104 °F and clean them. Remove the battery cover and dry the battery compartment. Do not repack until everything is completely dry. Always close the transport container when using in the field.

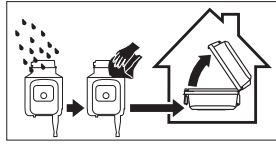

AP reflector pole

In case of water ingress in the AP reflector pole, remove the tip of the pole to release water.

Cables and plugs

Keep plugs clean and dry. Blow away any dirt lodged in the plugs of the connecting cables.

17

Technical Data

17.1

PoleHeight

Range	AP Reflector Pole	PoleHeight Minimum		PoleHeight Maximum		Snap-lock spacing	
		[m]	[ft]	[m]	[ft]	[m]	[ft]
	CRP4	1.55	-	2.20	-	0.05	-
	CRP5	-	6.0	-	7.0	-	1.0
	GLS51	1.55	-	2.20	-	0.05	-
	GLS51F	-	4.7	-	7.0	-	0.2

Accuracy in reading of PoleHeight

± 1.0 mm



Valid for engaged snap-lock positions of the AP Reflector Pole.



The centring accuracy of the attached prism is not included.

17.2

Tilt Compensation

Range

Tilt range

Tilt Compensation works in arbitrary alignments of the pole as long as the target has free line-of-sight to the total station and positions can be measured continuously.

Range from total station

The maximum measuring range between the tilted pole and the total station depends on the achievable target lock and the remote connection range, typically 300 m.



A total station with target locking and continuous distance measurement is required.



A RH18 is required on the total station to support AP20 Tilt Compensation.

Accuracy

Since the Tilt Compensation uses continuous total station observations for the determination of the pole tilt, the tilt accuracy depends on various factors.

- Angular accuracy of the total station
- Distance accuracy of the total station
- Target type
- EDM measurement frequency of the total station
- Environmental and atmospheric conditions
- Target height
- Level of pole tilt

The derived additional pole tip accuracy in 2D and 1D, given as root mean square, depends on the level of tilt and the used target height. The lower the target height, the higher the pole tip accuracy.

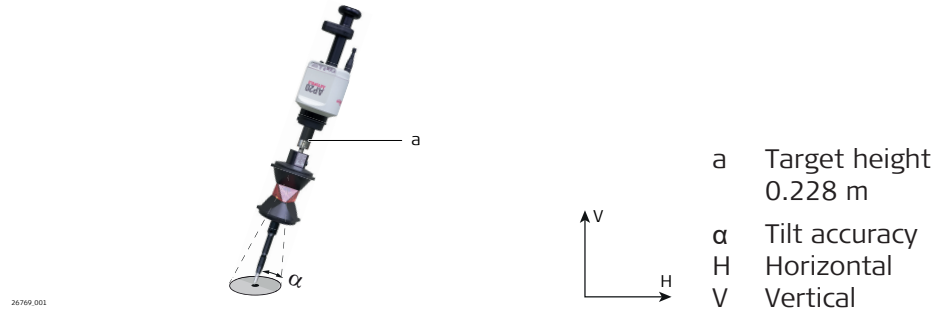
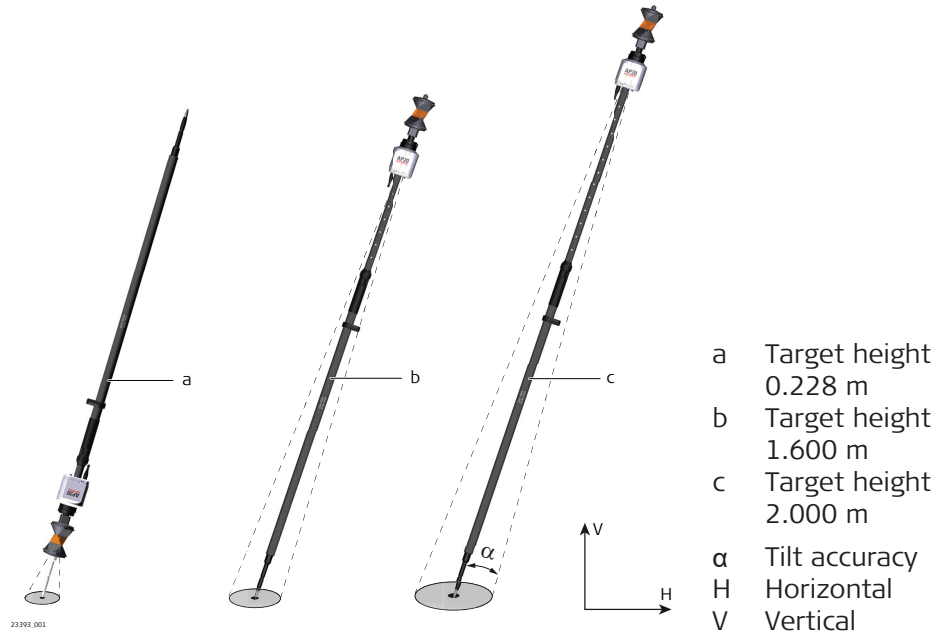

The less the pole is tilted from zenith/nadir to a horizontal pole alignment, the higher the pole tip accuracy.

	Target height	Additional pole tip uncertainty for tilt down to 90°, typically
Horizontal (2D)	0.228 m	1 mm + 0.1 mm/° tilt
	1.600 m	3 mm + 0.6 mm/° tilt
	2.000 m	4 mm + 0.7 mm/° tilt
	3.000 m	10 mm + 0.9 mm/° tilt
	4.000 m	16 mm + 1.2 mm/° tilt
Vertical (1D)	0.228 m	1 mm + 0.05 mm/° tilt
	1.600 m	1 mm + 0.05 mm/° tilt
	2.000 m	1 mm + 0.1 mm/° tilt
	3.000 m	1.5 mm + 0.6 mm/° tilt
	4.000 m	2.0 mm + 1.6 mm/° tilt



When using the AP20 as a hidden point pole with 3 m or 4 m pole length, avoid a deflection of the pole during point storage to minimise additional errors.

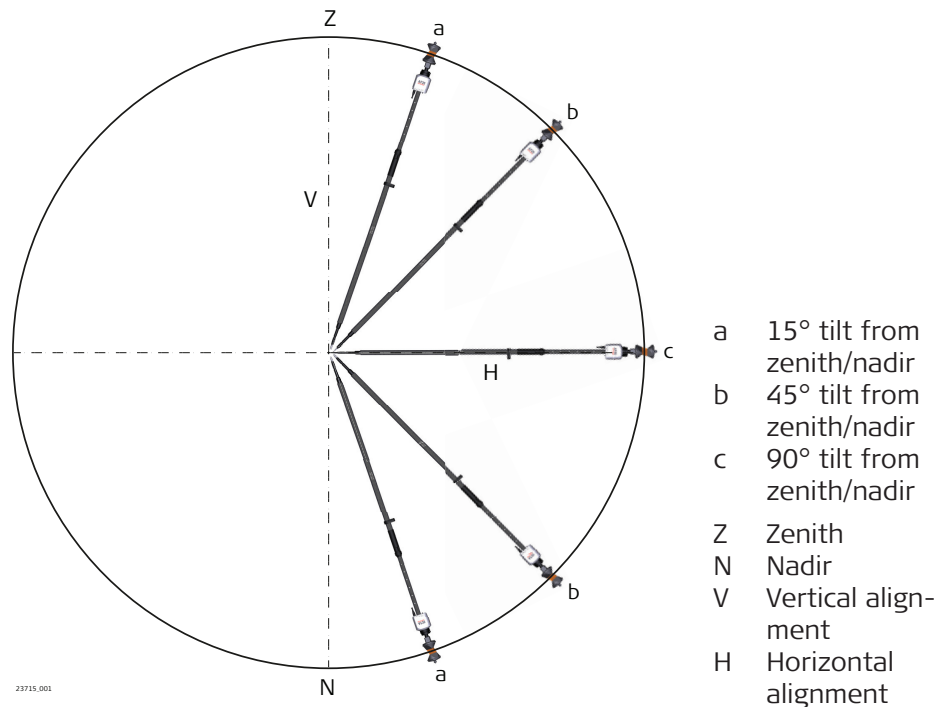

When carrying the AP20 on the pole:

- Avoid dropping it and toppling over.
- In case of mechanic shock, test measurements are recommended to check the accuracy.

Measurement principle

Combining the reflector position with attitude information from an Inertial Measurement Unit (IMU) results in a tilt compensated pole tip position.

17.3

TargetID

Range

Pole alignment	Range	
	[m]	[ft]
Vertical	150	500
Tilted $\pm 30^\circ$	100	325

TargetID uses PowerSearch technology. Measurements at the vertical limits of the PowerSearch fan or under unfavourable atmospheric conditions may reduce the maximum range.

Shortest measuring distance: 5 m

Separability

Number of different IDs: 16

Principle of TargetID

Type	Description
Principle	Digital image processing
Type	Infrared laser

 A total station with PowerSearch is required.

17.4

General Technical Data of the Product

AP20 dimensions



Weight

Type	Value
All AP20	0.4 kg
Internal battery	0.1 kg

Power consumption

Type	Power consumption	
	Typically	Maximum
AP20 H	1.2 W	1.5 W
AP20 ID	1.5 W	13.1 W
AP20 T	3.2 W	4.0 W
AP20	3.6 W	15.6 W

Instrument port

Name	Description
USB type C port	Cable connection from USB devices for firmware update

Internal battery

Type	Battery	Nominal Voltage	Capacity
GEB321	Li-Ion	7.2 V \approx	3.35 Ah

Operating times

Model	Operating time, typical
AP20 H	> 16 h
AP20 ID	

Environmental specifications

Model	Operating time, typical
AP20 T AP20	6 h

Temperature

Type	Operating temperature [°C]	Storage temperature [°C]
All AP20	-30 to +60	-40 to +80
Battery internal	-20 to +55	-40 to +70
All chargers	0 to +50	-40 to +70

Protection against water, dust and sand

	Protection
All AP20	IP67 (IEC 60529)
All chargers	Only operate in dry environments, for example in buildings and vehicles.

Pollution degree

Type	Pollution
All AP20	4 Electrical equipment for outdoor use
All chargers	2 Electrical equipment for office environment

Humidity

Type	Protection
All AP20	Max 95% non condensing The effects of condensation are to be effectively counteracted by periodically drying out the AP20.
All chargers	Only operate in dry environments, for example in buildings and vehicles.

Altitude

Type	Protection
All AP20	Unrestricted
All chargers	≤ 2000 m above sea level

17.5

Conformity to National Regulations

Labelling AP20

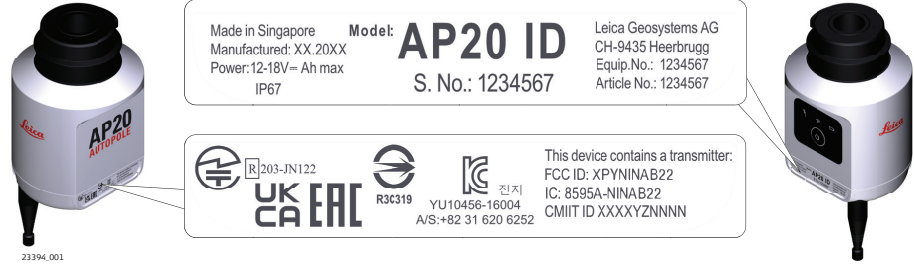

This device complies with part 15 of the FCC Rules. Operation is subject to the following two conditions: (1) This device may not cause harmful interference, and (2) this device must accept any interference received, including interference that may cause undesired operation.



24805.001

Labelling GEB321



24804.001

Frequency band

Type	Value
Bluetooth	2402 - 2480 MHz
NFC	13.56 MHz

Output power

Type	Value
Bluetooth	≤ 8 dBm (e.i.r.p)

Antenna

Type	Antenna	Gain
Bluetooth Classic	Planar Inverted-F Antenna (PIFA)	Internal antenna
Bluetooth Low Energy	1/4 wavelength whip antenna	3.5 dBi (Peak)

Type	Antenna	Gain
Near-Field Communication (NFC)	Coil flex	-

EU



Hereby, Leica Geosystems AG declares that the radio equipment type AP20 is in compliance with Directive 2014/53/EU and other applicable European Directives.

The full text of the EU declaration of conformity is available at the following Internet address: <http://www.leica-geosystems.com/ce>.

USA

Contains FCC ID: XPNINAB22 (AP20 H), XPNINAB22 (AP20 ID), RFD-AP20T (AP20 T), RFD-AP20T (AP20)
Part 15 B

This device complies with part 15 of the FCC Rules. Operation is subject to the following two conditions:

1. This device may not cause harmful interference, and
2. This device must accept any interference received, including interference that may cause undesired operation.

This equipment has been tested and found to comply with the limits for a Class B digital device, pursuant to part 15 of the FCC Rules.

These limits are designed to provide reasonable protection against harmful interference in a residential installation.

This equipment generates, uses, and can radiate radio frequency energy and, if not installed and used in accordance with the instructions, it may cause harmful interference to radio communications.

However, there is no guarantee that interference does not occur in a particular installation.

If this equipment does cause harmful interference to radio or television reception, which can be determined by turning the equipment off and on, the user is encouraged to try to correct the interference by one or more of the following measures:

- Reorient or relocate the receiving antenna.
- Increase the separation between the equipment and the receiver.
- Connect the equipment into an outlet on a circuit different from that to which the receiver is connected.
- Consult the dealer or an experienced radio/TV technician for help.

Canada

CAN ICES-003 B/NMB-003 B
IC: 8595A-NINAB22 (AP20 H), 8595A-NINAB22 (AP20 ID), 3177A-AP20T (AP20 T), 3177A-AP20T (AP20)

Canada Compliance Statement

This device contains licence-exempt transmitter(s)/receiver(s) that comply with Innovation, Science and Economic Development Canada's licence-exempt RSS(s). Operation is subject to the following two conditions:

1. This device may not cause interference
2. This device must accept any interference, including interference that may cause undesired operation of the device

Canada Déclaration de Conformité

L'émetteur/récepteur exempt de licence contenu dans le présent appareil est conforme aux CNR d'Innovation, Sciences et Développement économique Canada applicables aux appareils radio exempts de licence. L'exploitation est autorisée aux deux conditions suivantes:

1. L'appareil ne doit pas produire de brouillage
2. L'appareil doit accepter tout brouillage radioélectrique subi, même si le brouillage est susceptible d'en compromettre le fonctionnement

Japan

- This device is granted pursuant to the Japanese Radio Law (電波法).
- This device should not be modified (otherwise the granted designation number will become invalid).

Others

The conformity for countries with other national regulations has to be approved prior to use and operation.

Software Licence Agreement

This product contains software that is preinstalled on the product, or that is supplied to you on a data carrier medium, or that can be downloaded by you online according to prior authorisation from Leica Geosystems. Such software is protected by copyright and other laws and its use is defined and regulated by the Leica Geosystems Software Licence Agreement, which covers aspects such as, but not limited to, Scope of the Licence, Warranty, Intellectual Property Rights, Limitation of Liability, Exclusion of other Assurances, Governing Law and Place of Jurisdiction. Please make sure, that at any time you fully comply with the terms and conditions of the Leica Geosystems Software Licence Agreement.

Such agreement is provided together with all products and can also be referred to and downloaded at the Leica Geosystems home page at [Hexagon – Legal Documents](#) or collected from your Leica Geosystems distributor.

You must not install or use the software unless you have read and accepted the terms and conditions of the Leica Geosystems Software Licence Agreement. Installation or use of the software or any part thereof, is deemed to be an acceptance of all the terms and conditions of such Licence Agreement. If you do not agree to all or some of the terms of such Licence Agreement, you must not download, install or use the software and you must return the unused software together with its accompanying documentation and the purchase receipt to the distributor from whom you purchased the product within ten (10) days of purchase to obtain a full refund of the purchase price.

Open Source information

The software on the product may contain copyright-protected software that is licenced under various open source licences.

Copies of the corresponding licences

- are provided together with the product (for example in the About panel of the software)
- can be downloaded on <http://opensource.leica-geosystems.com>

If foreseen in the corresponding open source licence, you may obtain the corresponding source code and other related data on <http://opensource.leica-geosystems.com>.

Contact

opensource@leica-geosystems.com in case you need additional information.



819179-6.0.0en

Original text (819179-6.0.0en)

Published in Switzerland, © 2023 Leica Geosystems AG



- when it has to be **right**



Leica Geosystems AG

Heinrich-Wild-Strasse
9435 Heerbrugg
Switzerland

www.leica-geosystems.com

